

CHEMISTRY PUMPING UNIT SERIES

PC 3010 NT VARIO select

PC 3016 NT VARIO select

PC 3012 NT VARIO select

PC 3012 NT VARIO select EKP



Instructions for use

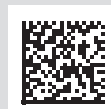

Original instructions**Keep for future use!**

This document may only be used and distributed in its complete and original form. It is the user's responsibility to ensure the validity of this document with respect to the product.

Manufacturer:

VACUUBRAND GMBH + CO KG

Alfred-Zippe-Str. 4

97877 Wertheim

GERMANY

Main office:	+49 9342 808-0
Sales:	+49 9342 808-5550
Service:	+49 9342 808-5660
Fax:	+49 9342 808-5555

Email: info@vacuubrand.com

Web: www.vacuubrand.com

*Thank you for purchasing this product from **VACUUBRAND GMBH + CO KG**. You have chosen a state-of-the-art, high-quality product.*

TABLE OF CONTENTS

1	About this manual	5
1.1	User information	5
1.2	Layout of the instructions for use	6
1.3	Presentation conventions	7
1.4	Symbols and pictograms	8
1.5	Action instructions.....	9
1.6	Abbreviations	9
1.7	Explanation of terms.....	11
2	Safety instructions	12
2.1	Use	12
2.1.1	Proper use	12
2.1.2	Improper use.....	12
2.1.3	Foreseeable misuse	13
2.2	Responsibilities.....	14
2.3	Target group description.....	15
2.4	Protective clothing.....	16
2.5	Safety measures.....	16
2.6	Laboratory and work materials.....	17
2.7	Possible sources of danger.....	18
2.8	Motor protection	21
2.9	ATEX device category.....	21
2.10	Disposal	22
3	Product description	23
3.1	Basic configuration of pumping unit series.....	23
3.2	Chemistry pumping unit series	24
3.3	Condensers and coolers	25
3.3.1	Separator/condenser at inlet.....	25
3.3.2	Condenser at outlet.....	25
3.4	Application example	26
4	Installation and connection	27
4.1	Transport.....	27
4.2	Installation	28
4.3	Holding base controller	30
4.4	Connection (supply connections)	31
4.4.1	Vacuum connection (IN).....	31

4.4.2	Outlet connection (OUT)	33
4.4.3	Coolant connection on the emission condenser	34
4.4.4	Venting connection.....	38
4.4.5	Gas ballast GB	39
4.5	Electrical connection	41
5	Operation	43
5.1	Switching on.....	43
5.2	Operation with controller.....	44
5.2.1	Operator interface	44
5.2.2	Operation	46
5.2.3	Operation with gas ballast	47
5.3	Switching off (decommissioning)	48
5.4	Storage	49
6	Troubleshooting	50
6.1	Technical assistance	50
6.2	Error – cause – remedy	50
7	Cleaning and maintenance	54
7.1	Information on service activities.....	55
7.2	Cleaning.....	57
7.2.1	Housing surface	57
7.2.2	Emptying the glass flask.....	58
7.2.3	Cleaning or replacing PTFE molded hoses.....	58
7.3	Vacuum pump maintenance	59
7.3.1	Maintenance items	59
7.3.2	Preparation	59
7.3.3	Replacing the membrane and valves	63
7.3.4	Device fuse replacement	81
8	Annex	82
8.1	Technical data.....	82
8.2	Materials affected by media	85
8.3	Rating plate	86
8.4	Order data	88
8.5	Service information	90
8.6	EU declaration of conformity	91
8.7	UKCA conformity declaration.....	92
	Index	93

1 About this manual

This User manual is part of the product you have purchased.

This instruction manual is valid for all pumping unit models, together with the instruction manual of the **VACUU·SELECT** controller, and is intended specifically for operators.

1.1 User information

Safety

Instruction manual
and safety

- Read the User manual carefully before using the product.
- Store the User manual in a place where it is accessible and close at hand at all times.
- Correct use of the product is essential for safe operation. Above all else, please follow the safety instructions!
- In addition to the information in this User manual, please also observe the applicable national regulations on accident prevention and occupational safety.

General

General information

- When passing this product on to third parties, please also include the User manual.
- All figures and drawings are examples and are solely intended for the purpose of better understanding.
- We reserve the right to make technical changes in the course of continuous product improvement.
- In the interest of readability, Pumping unit is equally used in place of the product name Chemistry pumping unit PC 301x NT VARIO select.

Copyright

Copyright® and
copyright law

The content of this User manual is protected by copyright law. Copies for internal purposes are permitted (e.g., for training).

© **VACUUBRAND GMBH + CO KG**

Contact

Please contact us

- In case of an incomplete User manual, you can request a replacement from us. Alternatively, our download portal is available to you: www.vacuubrand.com
- Call us or write to us if you have any other questions about the product, need additional information or want to give us feedback on the product.
- When you contact our service department, please have the serial number and product type on hand --> see the rating plate on the product.

1.2 Layout of the instructions for use

Organization of instructions

The instructions for use for the pumping unit, the controller and available accessories are organized in a modular format; this means that the instructions are divided into individual, separate instruction brochures.

Instruction modules

Pumping unit series and modular instructions for use

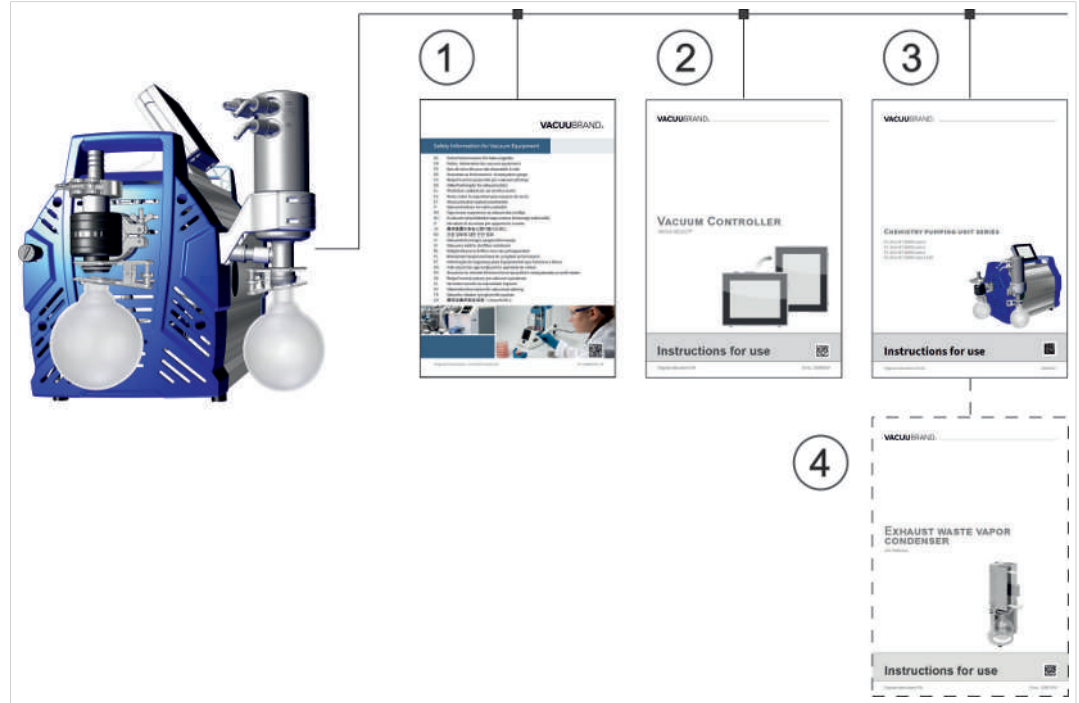

Meaning

- 1** Safety information for vacuum equipment
- 2** Instruction manual: Vacuum controller – Control and operation
- 3** Instruction manual: Pumping unit – Connection, operation, maintenance, mechanical system
- 4** Optional instruction manual: Accessories

1.3 Presentation conventions

Warning messages

Presentation of warning messages

	DANGER
	<p>Warning of imminent danger.</p> <p>Failure to observe this warning may result in imminent danger to life or severe injury.</p> <ul style="list-style-type: none"> ➤ Please follow the instructions for prevention!

	WARNING
	<p>Warning of a potentially dangerous situation.</p> <p>Failure to observe this warning may result in danger to life or serious injury.</p> <ul style="list-style-type: none"> ➤ Please follow the instructions for prevention!

	CAUTION
	<p>Indicates a potentially dangerous situation.</p> <p>Failure to observe this caution may result in minor injuries or material damage.</p> <ul style="list-style-type: none"> ➤ Please follow the instructions for prevention!

NOTICE	
<p>Reference to a potentially harmful situation.</p> <p>Failure to observe this note may result in material damage.</p>	

Additional information

Presentation of information and tips

	<p>General information about:</p> <ul style="list-style-type: none"> ⇒ Tips and tricks ⇒ Helpful functions or activities
---	---

1.4 Symbols and pictograms

This instruction manual uses symbols and pictograms. These safety symbols and pictograms indicate specific dangers or requirements when handling the product. Warning signs with safety symbols on the product provide a visualization of the potential hazard.







Safety symbols

Explanation of safety symbols

	General danger sign.		Warning of electrical voltage.
	Warning of hot surface.		Electrostatically sensitive components ESD.
	General mandatory action sign.		Disconnect power plug from electrical outlet.
	Wear protective gloves.		Wear protective goggles.

Other symbols and pictograms

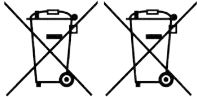
Additional symbols

	Positive example – Right! Result – o.k.		Negative example – Wrong!
	Reference to content in this User manual.		Reference to content in supplementary documents.
	Ensure sufficient air circulation.		
	Electrical and electronic equipment and batteries must not be disposed of in household waste at the end of their service life.		
	Inlet current arrow – vacuum connection		
	Outlet current arrow – exhaust gas		

1.5 Action instructions

Action instructions (simple)

- Action instructions
- ⇒ You are requested to take action.
 - Result of the action

Action instructions (multiple steps)

1. First action step
2. Next action step
 - Result of the action

Action instructions that require several steps must be followed in the order they are described.

Action instructions (image description)

-> Example
Principle presentation
Operating steps
presented in images

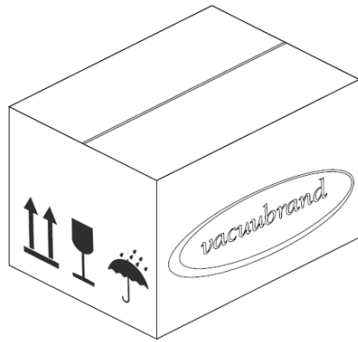
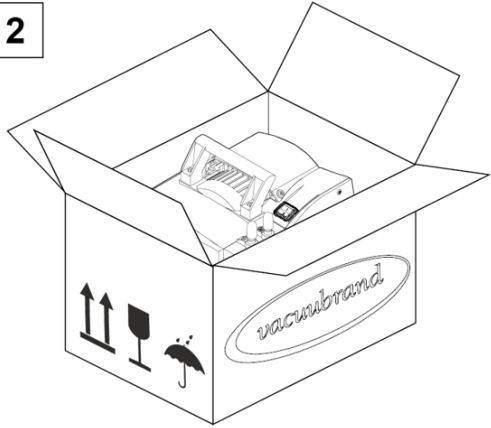
<div data-bbox="438 963 502 1019" style="border: 1px solid black; padding: 2px; width: 30px; margin: 0 auto;">1</div> 	<div data-bbox="981 963 1045 1019" style="border: 1px solid black; padding: 2px; width: 30px; margin: 0 auto;">2</div> 
<p>1. First action step.</p>	<p>2. Next action step.</p> <ul style="list-style-type: none"> <input checked="" type="checkbox"/> Interim result or result of the action

1.6 Abbreviations

Abbreviations used

abs.	Absolute
AK	Separator flask
ATM	Atmospheric pressure (bar graph, program)
di	Internal diameter
DN	Diameter nominal
EK	Emission condenser
EKP	Peltronic emission condenser or Peltronic EK

EX ¹	Outlet (exhaust, exit), outlet connection
	ATEX device marking
Gas-type ind.	Gas type independent
GB	Gas ballast
Size	Size
IK	Immission condenser
IN ¹	Inlet, vacuum connection
KF	Small flange
Max.	Maximum value
Min.	Minimum value
o. EK	Without emission condenser
PC ...	Chemistry pumping unit with type code
RMA No.	Return authorization number
SW	Wrench size (tool)
TE	Dry ice condenser
resp.	Responsible person(s)

Materials

ECTFE	Ethylene chlorotrifluoroethylene
ETFE	Ethylene/tetrafluoroethylene
FEP	Perfluoro(ethylene-propylene)
FFKM	Perfluoroelastomer
FPM	Fluoropolymer rubber
NBR	Nitrile butadiene rubber
PA	Polyamide
PE	Polyethylene
PET	Polybutylene terephthalate
PFA	Perfluoroalkoxy
PP	Polypropylene
PPS	Polyphenylene sulphide
PTFE	Polytetrafluorethylene

¹ Labeling on vacuum pump or component, see also product specific abbreviations under: Chemistry pumping unit series

1.7 Explanation of terms

Product-specific terms

Separator flask	Glass flask/separator installed at the inlet or outlet.
Emission condenser²	Cooling condenser with collecting flask installed at the outlet (pressure side).
Fine vacuum	Pressure measurement range in the vacuum technology, from: 1 mbar–0.001 mbar (0.75 Torr–0.00075 Torr)
Rough vacuum	Pressure measurement range in the vacuum technology, from: Atmospheric pressure–1 mbar (atmospheric pressure–0.75 Torr)
Immission condenser²	Cooling condenser with collecting flask installed at the inlet (vacuum side).
PC 301x NT VARIO select	Vacuum pumping unit NT version with speed control for precise vacuum regulation with VACUU·SELECT controller and VACUU·SELECT sensor.
Peltronic	Electronic cooler with Peltier elements installed at the outlet (pressure side); condenses solvent vapors without external cooling medium.
Dry ice condenser²	Cooling condenser with collecting flask and dry ice as cooling medium installed at the outlet (pressure side).
VACUU·BUS	VACUUBRAND bus system for the communication of peripheral devices with VACUU·BUS-capable measuring equipment and controllers.
VACUU·BUS address	Address that enables a clear assignment of the VACUU·BUS client in the bus system, e.g. for the connection of several sensors of the same measurement range.
VACUU·BUS client	Peripheral device or components with VACUU·BUS connection, which is integrated in the bus system, e.g. sensors, valves, level indicators, etc.
VACUU·BUS plug	4-pin round plug for the VACUUBRAND bus system.
VACUU·BUS configuration	Using a measuring device or controller to assign a new VACUU·BUS address to a VACUU·BUS component.
VACUU·SELECT	Vacuum controller, controller with touchscreen; consisting of control unit and vacuum sensor.
VACUU·SELECT sensor	Vacuum sensor with integrated venting valve.
VARIO drive	Speed control for vacuum pumps; the motor only runs as fast as needed.

² Only suitable for the condensation of vapors.

2 Safety instructions

The information in this chapter must be observed by all persons who work with the device described here.

The safety instructions are valid for all life stages of the product.

2.1 Use

The device may only be used in perfect technical condition.

2.1.1 Proper use

Proper use

A chemistry pumping unit of the PC 301x NT VARIO select product series is a vacuum system consisting of a vacuum pump, controller, vacuum sensor, cooler, and separator for generating and regulating a rough vacuum in systems designed for this purpose.

Attached coolers (emission condenser, immission condenser, dry ice cooler, Peltronic emission condenser), including separator and flask, are designed exclusively for condensing vapors.

The vacuum system should only be used in a dry, non-explosive environment.

Proper use also includes:

- following the instructions in the document *Safety information for vacuum equipment*,
- observing the instruction manual,
- observing the instruction manual of connected components,
- complying with inspection and maintenance intervals and having this carried out only by qualified personnel,
- using only approved accessories or replacement parts.

Any other use or use beyond this is considered improper.

2.1.2 Improper use

Improper use

Improper use or any use that does not correspond with the technical data can lead to personal or material damage.

Improper use is considered:

- use that contradicts the proper use,
- operation in unauthorized ambient and operating conditions,
- operation with obvious faults, damages or defective safety equipment,
- unauthorized extensions and modifications, especially when these compromise safety,
- use in an incomplete state,
- operation with sharp-edged objects,
- pulling connectors on the cable out of the socket,
- vacuuming, pumping and condensing solid materials or liquids.

2.1.3 Foreseeable misuse

Misuse In addition to improper use, there are other types of use that are forbidden when handling the device.

Forbidden types of use are primarily:

- use on people or animals,
- setup and operation in a potentially explosive environment,
- use in mining or underground,
- using the product to generate pressure,
- fully exposing vacuum equipment to the vacuum,
- submerging vacuum equipment in liquids, exposing to spray water or steam spraying,
- pumping oxidizing and pyrophoric materials, liquids or solids,
- pumping media that is hot, unstable, potentially explosive or explosive,
- pumping materials that can react explosively under impact and/or increased temperature without air supply.

The user must prevent the penetration of foreign bodies, hot gases and flames.

2.2 Responsibilities

Follow the instructions for all actions as they are specified in this instruction manual.

Responsibilities of the operator

Operator responsibilities

The operator defines the responsibilities and ensures that only trained or qualified personnel work on the vacuum system. This applies in particular to connection, assembly work, maintenance tasks and fault elimination.

Users in the competency areas listed in the → **Target group description on page 15** must have the corresponding qualification for the listed activities. Only qualified electricians are permitted to carry out special work on electrical equipment.

Personnel responsibilities

Personnel responsibilities

For activities that require protective clothing, the personal protection equipment specified by the operator must be worn.

When the vacuum system is not in proper operating condition, it must be secured against accidental restart.

- ⇒ Always work with safety in mind.
- ⇒ Follow the operator's instructions and the national regulations on accident prevention and occupational safety.



Personal conduct can contribute to the prevention of occupational accidents.

2.3 Target group description

Target groups The instruction manual must be read and observed by every person entrusted with one of the following activities.

Personnel qualification

Qualification description	Operator	Laboratory personnel, e.g. chemists, physicists, lab technicians
	Qualified employee	Person with professional qualification for maintenance and/or repair in the field of: mechanical systems, electrical systems or laboratory equipment. The assigned work can be assessed and potential dangers detected.
	Responsible specialist	Qualified employee with additional field, department or division responsibility who is assigned by the operator.

Responsibility matrix

Who-does-what matrix	Task	Operator	Qualified employee	Responsible specialist
	Installation	x	x	x
	Initial operation	x	x	x
	Network integration			x
	Operation	x	x	x
	Fault reporting	x	x	x
	Fault elimination	(x)	x	x
	Device fuse replacement		x	x
	Maintenance		x	x
	Repair ³		x	x
	Repair order			x
	Cleaning, simple	x	x	x
	Emptying separator	x	x	x
	Decommissioning	x	x	x
	Decontamination ⁴		x	x

³ See also homepage: VACUUBRAND > Support > [Repair instructions](#)

⁴ Or have decontamination carried out by a qualified service provider.

2.4 Protective clothing



Special protective clothing is not required for operation of the vacuum pump. Follow the operator's instructions for your workplace.

For cleaning, maintenance and repair work, we recommend wearing fully adequate protective gloves, clothing and glasses.

- ⇒ Wear your personal protection equipment when handling chemicals.

2.5 Safety measures

Manufacturer measures

Products of **VACUUBRAND GMBH + CO KG** are subject to high quality control requirements in terms of safety and operation. Each product is put through an extensive test program before delivery.

Operator measures

Operator measures

- ⇒ Use your vacuum device only when you have understood the instruction manual and the operation.
- ⇒ Replace defective components immediately (e.g., broken power cables, defective hoses or flasks).
- ⇒ Use only original accessories and components that are designed for the vacuum technology, e.g., vacuum hose, separator, vacuum valve, etc.
- ⇒ When handling contaminated parts, follow the relevant regulations and protection measures; this also applies to sending parts in for repair.
- ⇒ For repairs, send us the carefully filled out and signed **Clearance Certificate** **before** you send your product in for repair. It must be possible to exclude hazardous substances for all repairs sent to our service department.

2.6 Laboratory and work materials



DANGER

Hazardous substances leak at the outlet.

When operating the vacuum device, hazardous, toxic substances can leak into the ambient air at the outlet.

- Observe the operating instructions and safety regulations when handling hazardous substances and dangerous media.
- Take into account that adhesive process media can present a danger to humans and the environment.
- Use and install suitable separators and filters for your activity.
- Work with fume cupboards that are designed for the hazardous substances used and offer maximum protection for people and the environment.

Dangers posed by different substances

Pumping different substances

Pumping different substances or media can trigger a reaction between materials.

Work materials that leak into the vacuum pump with the gas flow can damage the vacuum pump. Hazardous substances can form deposits in the vacuum pump.

Possible protective measures

Protective measures, depending on the application

- ⇒ Rinse the vacuum pump with inert gas or air before you change the pumping medium.
- ⇒ Use inert gas to dilute critical mixtures.
- ⇒ Prevent the release of hazardous, toxic, explosive, corrosive, health-damaging or environmentally harmful fluids, gases or vapors, e.g. by using suitable laboratory equipment with an extraction system and ventilation control.
- ⇒ Protect the inside of the vacuum pump from deposits or humidity, e.g. by using a gas ballast feed system.
- ⇒ Observe the interactions and possible chemical reactions of the pumped media.

- ⇒ Check the compatibility of the pumped substances with the medium-affected materials of the pumping unit.
- ⇒ Contact us if you have concerns about using your vacuum pump with special work materials or media.

Preventing foreign bodies inside the pump

Observing the vacuum pump design

The vacuum pump is designed for pumping gases. Particles, liquids and dust are therefore not permitted inside the vacuum pump.

- ⇒ Do not pump any substances that can form deposits inside the vacuum pump.
- ⇒ Install suitable separators and/or filters in front of the inlet. Suitable filters are chemical resistant, clog-free and ensure a constant flow rate.
- ⇒ Replace porous vacuum hoses promptly.

2.7 Possible sources of danger

Considering mechanical stability

Observing mechanical stability

Due to the high compression ratio of the pumps, a higher pressure can build up at the outlet than the mechanical stability of the system allows.

- ⇒ Always ensure that the outlet line is open and free of pressure. To guarantee an unobstructed emission of gases, the outlet must remain unblocked.
- ⇒ Prevent uncontrolled excess pressure (e.g., from shut-off or blocked piping system, condensate, or clogged outlet line).
- ⇒ At the gas connections, the connections for inlet (IN) and outlet (EX) may never be confused.
- ⇒ Observe the max. pressure at the inlet and outlet of the pump as well as the max. permissible differential pressure between inlet and outlet, in accordance with the *technical data*.
- ⇒ The system to be evacuated and all hose connections must be mechanically stable.
- ⇒ Attach the coolant hoses to the hose nozzles so that they do not come loose unintentionally.

Preventing condensate return flow

Preventing backlog
in the exhaust line

Condensate can damage the pump head. Condensate must never flow back through the outlet hose line into the outlet and into the pump head. Liquid may not accumulate inside the outlet hose. Liquid may not accumulate inside the outlet hose.

- ⇒ Prevent condensate return flow by using a separator. Condensate is not allowed to enter the inner housing through the hose lines.
- ⇒ If possible, lay the outlet hose so that it is descending from the outlet (i.e., running downward) so that no backlog can form.
- ⇒ Incorrect measurement due to blocked vacuum line (e.g., condensate in the vacuum line) can distort the measurements of the vacuum sensor.
- ⇒ Prevent excess pressure in the suction hose.

Dangers during ventilation

Looking out for dangers during ventilation

Depending on the process, a potentially explosive mixture can form in installations or other dangerous situations can occur.

- ⇒ When flammable substances are present, use only inert gas (e.g., nitrogen) for ventilation (max. 1.2 bar/900 Torr abs.).

Dangers due to residual energy

Possible residual energies

After the vacuum pump has been switched off and disconnected from the power network, dangers may still be present due to residual energies:

- Thermal energy: Motor waste heat, hot surface, compression heat.
- Electrical energy: Installed condensers have a discharge time of up to 3 minutes.

Please note the following before performing actions:

- ⇒ Allow the vacuum pump to cool down.
- ⇒ Wait until the capacitors have discharged.

Dangers due to hot surfaces or overheating

- Surface temperatures Depending on the operating and ambient conditions, hot surfaces may pose a hazard. Eliminate danger from hot surfaces.
- ⇒ Avoid direct contact with the surface or wear heat-resistant safety gloves if contact cannot be excluded.
 - ⇒ Provide contact protection if the surface temperature should be elevated on a regular basis.
 - ⇒ Allow the vacuum pump to cool down before performing maintenance tasks.
- Overheating The vacuum pump can become damaged due to overheating. Potential causes are insufficient air supply to the cooling fan and/or non-compliance with minimum distances.
- ⇒ When setting up the device, observe a minimum distance of 5 cm between the cooling fan and adjacent parts (e.g., housing, walls).
 - ⇒ Always ensure that there is sufficient air supply; if necessary, provide an external forced ventilation system.
 - ⇒ Place the device on a stable surface. A soft surface (e.g., foam as sound absorber) can impair and block the supply of air.
 - ⇒ Clean dirty ventilation slots.
 - ⇒ Remove any covers not belonging to the product from the device before putting it into operation.
 - ⇒ Avoid applying too much heat due to hot process gases.
 - ⇒ Observe the maximum permissible media temperature in accordance with the *technical data*.

Ensure that signs are readable

- Labels and signs Make sure that instructions and signs attached to the device remain in a readable condition:
- ⇒ Labels for connections
 - ⇒ Warning and information signs
 - ⇒ Motor data and type plates

2.8 Motor protection

Overheating protection

A temperature sensor is integrated in the motor as overload protection. The pump is switched off in the event of overtemperature.

Restart procedure

Attention: Only manual reset possible. If the pump is switched off because of this safety measure, the fault must be reset manually: Acknowledge the error message on the controller → Switch off the pump or pull out the mains plug → Determine and eliminate the cause of the fault → Allow the pump to cool down and switch it on again.

2.9 ATEX device category

Installation and explosive environment

Installation and operation in areas where an explosive atmosphere can occur in dangerous quantities is not permitted.

The user is responsible for assessing the hazards for the device, so that any protection measures can be implemented for the installation and safe operation.

The ATEX certification applies only for the inner area in contact with media of the pumping unit, not for the surrounding area.

ATEX device marking

ATEX device category



Vacuum devices labeled with the marking Ex are certified in accordance with the ATEX marking on the type plate.

Operation is only permitted in technically sound condition.

The product is designed for a low degree of mechanical danger and must be installed so that it cannot be mechanically damaged from the outside.

ATEX device category and peripheral devices

The ATEX device category of the pumping unit depends on the connected components and the periphery. Components and peripheral devices must have the same or higher ATEX classification.

Preventing sources of ignition

The use of ventilation valves is only permitted if it is ensured that this normally does not produce explosive mixtures in the interior of the pumping unit or that in all probability explosive mixtures are only briefly or rarely produced.

⇒ If necessary, ventilate with inert gas.

Information about the ATEX device category can be found online: [ATEX information](#)

Explanation of usage
conditions X
Type plate example



Restrictions on operating conditions

Meaning for devices marked with **X** :

- The devices have a low mechanical protection and must be installed so that they cannot be mechanically damaged from the outside; e.g., installing pumping units with impact protection, attaching shatter protection for glass flasks, etc.
- The devices are designed for an ambient and media temperature of +10 °C to +40 °C during operation. These ambient and media temperatures must never be exceeded. When conveying/measuring non-explosive gases, extended gas suction temperatures apply, see chapter: Technical data, media temperature (gas).

2.10 Disposal



NOTICE

Improper disposal of electronic components can result in damage to the environment.

Electronic equipment contains hazardous materials that can damage the environment or human health. Discarded electronic equipment also contains valuable raw materials, which can be recovered if properly disposed of for recycling.

End users are required by law to bring waste electrical and electronic equipment to an approved collection site.

- ⇒ It is your responsibility to save and delete any data before disposing of your electronic device.
- ⇒ Please properly dispose of electrical waste and electronic components at the end of their service life.
- ⇒ Observe the national regulations on disposal and environmental protection.

3 Product description

Pumping units of the PC 301x NT VARIO select series essentially consist of a diaphragm pump controlled by VARIO drive, a VACUU·SELECT type vacuum controller with VACUU·SELECT sensor, and a cooler with separator. There are different versions of chiller. The difference lies in how the chillers operate.

A frequency converter and a switched-mode power supply are installed in the pump.

3.1 Basic configuration of pumping unit series

View and basic configuration
PC 301x NT VARIO
select

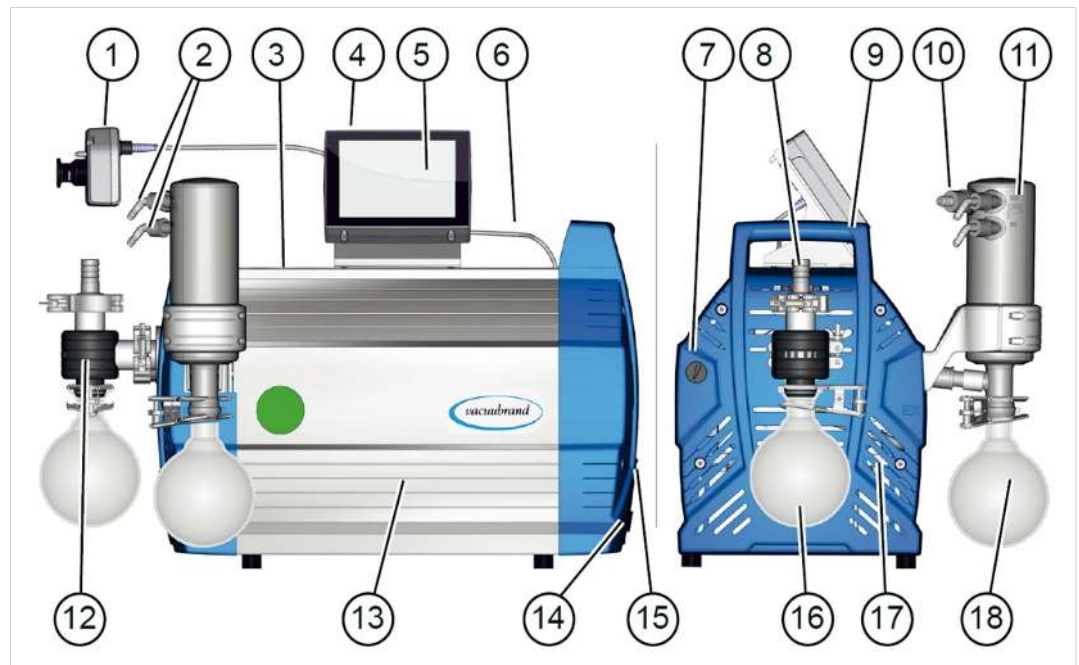

Meaning

1	VACUU·SELECT sensor, mount on suction line
2	Coolant connections
3	Chemistry diaphragm pump
4	On/Off button VACUU·SELECT controller
5	VACUU·SELECT control unit
6	VACUU·BUS cable (power supply controller + control cable)
7	Gas ballast valve
8	Vacuum connection – inlet IN
9	Handle (2x)
10	Outlet connection – outlet EX
11	Emission condenser EK
12	Inlet separator

- 13** Side panel
- 14** Power connection to pumping unit, On/Off switch (rocker switch) + device fuse
- 15** Rating plate
- 16** Round bottom flask at the inlet
- 17** Housing section with handle, front
- 18** Round bottom flask at outlet

3.2 Chemistry pumping unit series

Overview of chemistry pumping units

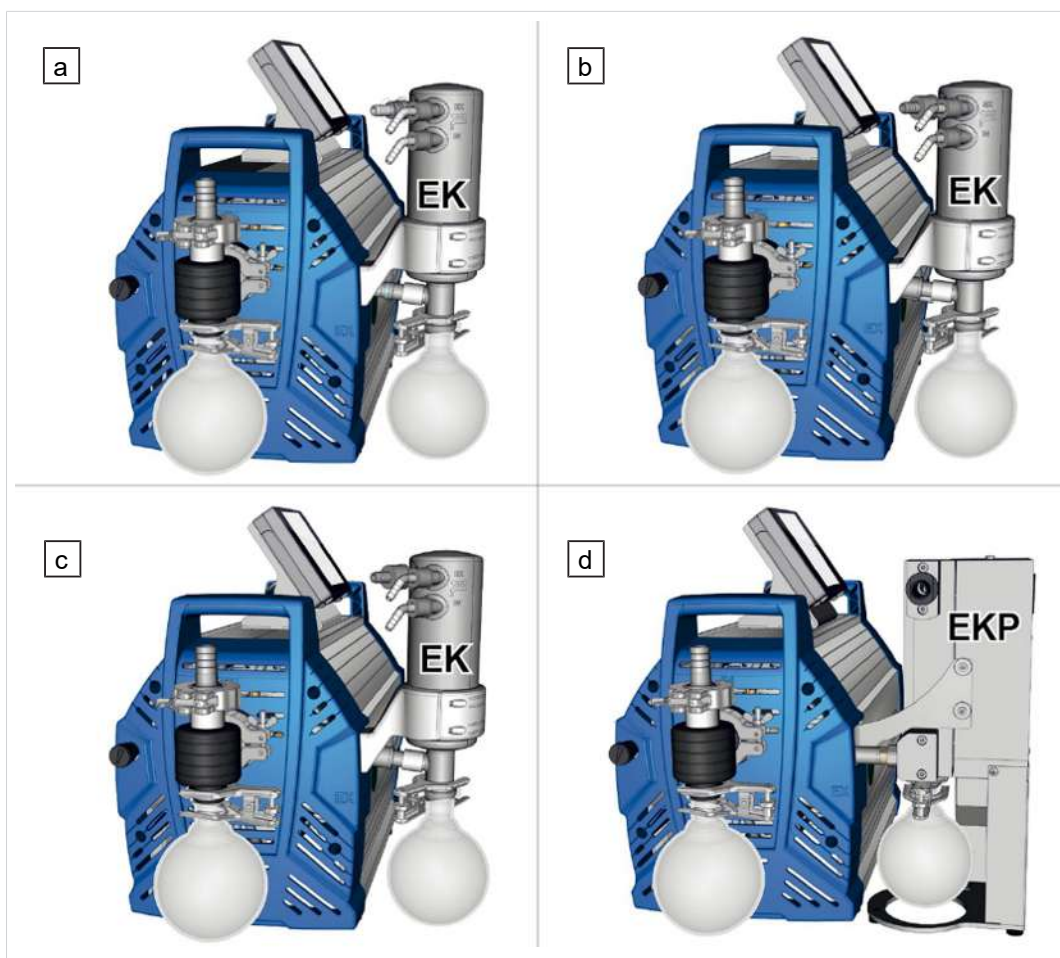

Meaning

Chemistry pumping unit	Pump head	Stages	AK	EK	EKP
a PC 3010 NT VARIO select	8	4	●	●	
b PC 3016 NT VARIO select	8	1	●	●	
c PC 3012 NT VARIO select	8	3	●	●	
d PC 3012 NT VARIO select EKP	8	3	●		●

Product-specific abbreviations

Product-specific abbreviations

AK	Separator flask, installed at inlet or outlet
EK	Emission condenser, installed at outlet
EKP	Peltronic emission condenser, installed at outlet
PC	Chemistry pumping unit with type code

3.3 Condensers and coolers

3.3.1 Separator/condenser at inlet

Connection at the separator flask

Connections on the AK

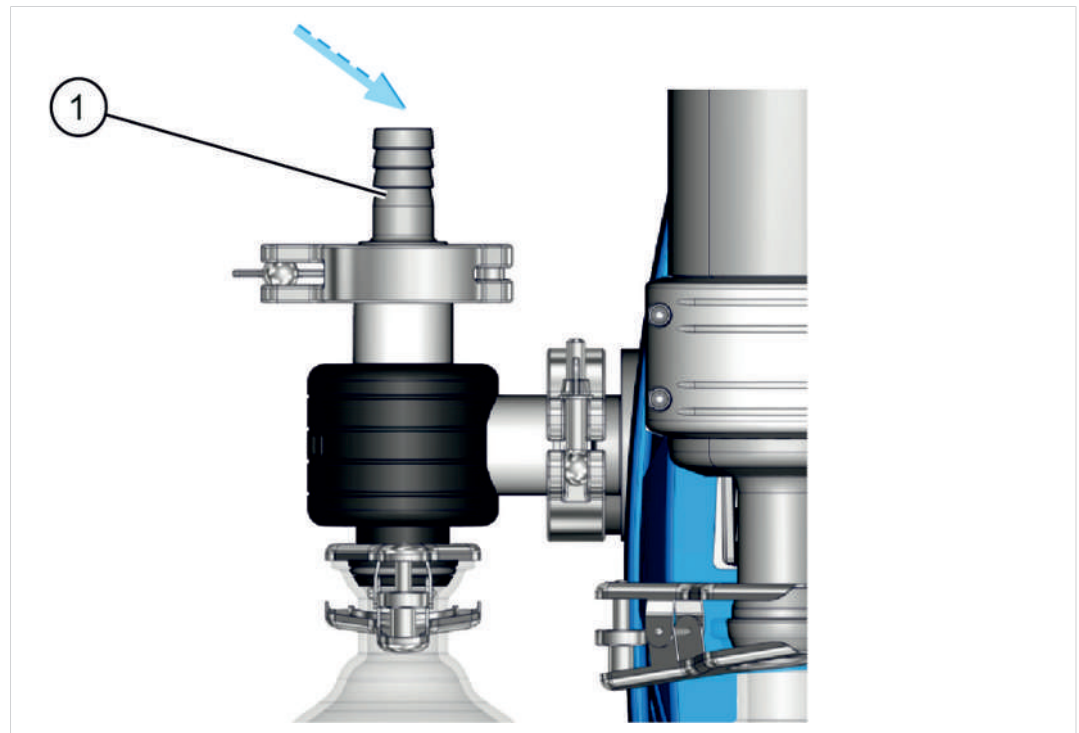

Meaning

1 Inlet connection vacuum IN

3.3.2 Condenser at outlet

Connection and coolant on the vapor condenser

Connections on the EK



Meaning

- 1 Outlet connection coolant EX
- 2 Inlet connection coolant IN (e.g., water)
- 3 EX outlet connection (gas/pumped media)

3.4 Application example

Local vacuum network

→ Example
Local area vacuum
network

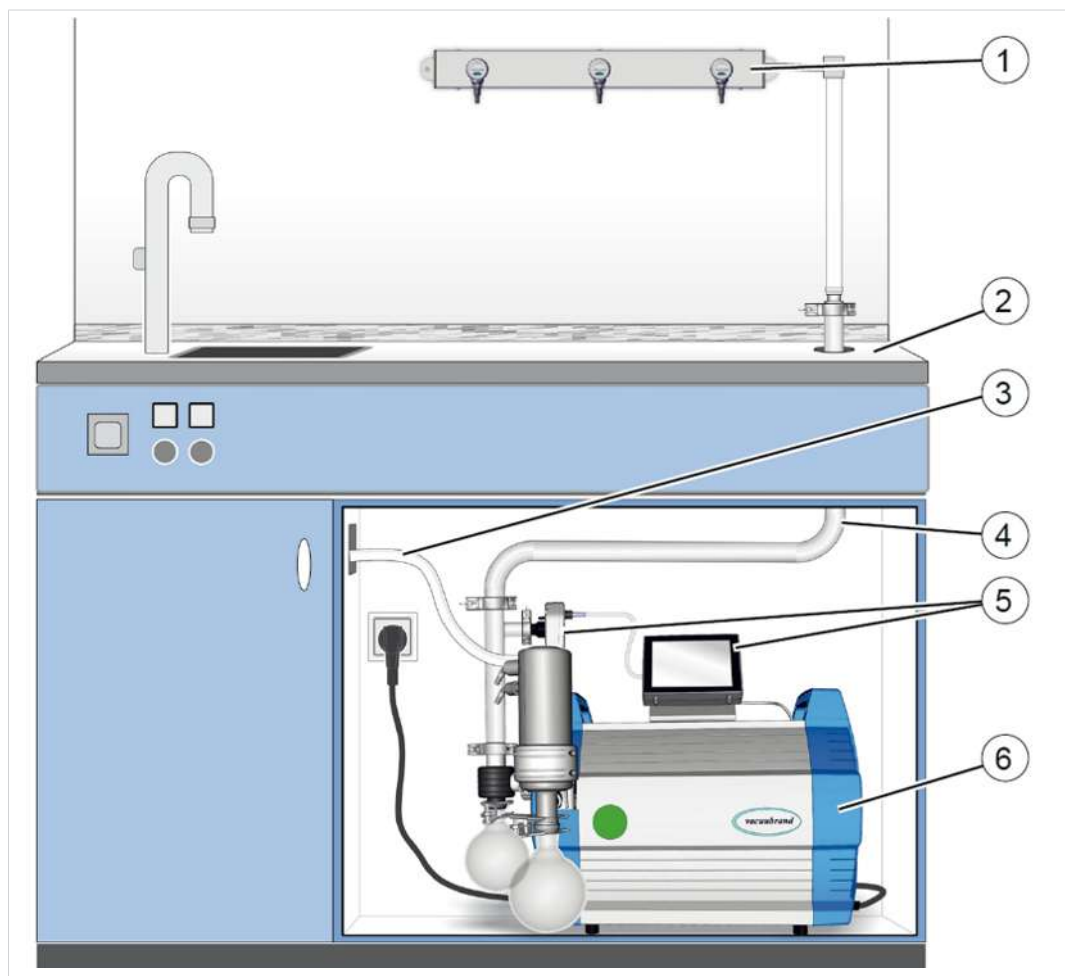

Meaning

- 1 Example of use: VACUU-LAN®, network arrangement with three valve modules
- 2 Laboratory furniture
- 3 Outlet hose (diverted into a fume hood)
- 4 Vacuum tubing
- 5 VACUU-SELECT control unit + VACUU-SELECT sensor
- 6 **PC 3012 NT VARIO select** vacuum pumping unit

4 Installation and connection

4.1 Transport



The original packaging is customized to your product for safe transport.

⇒ If possible, keep the original packaging, e.g. for sending in for repairs.

Incoming goods

- ⇒ Check the delivery immediately after receipt for any transport damage and for completeness.
- ⇒ Promptly report transport damage to the supplier in writing.

Unpacking

→ Example
Pumping unit in original packaging with enclosed package

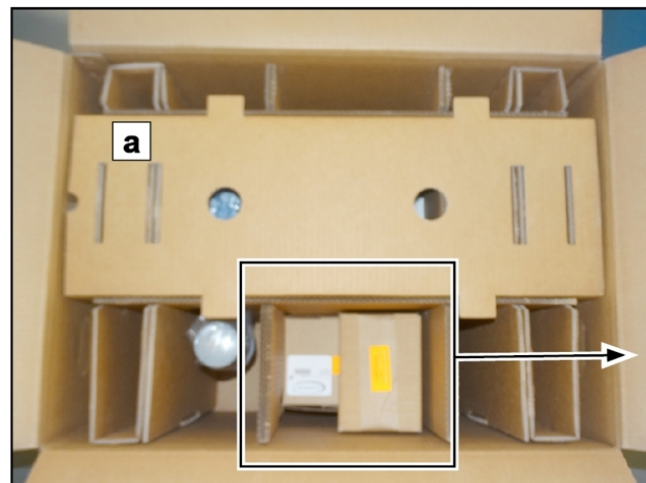

- (a) = Pumping unit
- (b) = Glass flask + accessories
- (c) = Manual, cable, inlet
- (d) = Controller, vacuum sensor, cable

1. Remove all enclosed packages from their original packaging and unpack them.
2. Compare the scope of delivery with the delivery note.



Please note that a pumping unit can weigh approx. 30-34 kg. We recommend using a lifting aid. Lift the unit out of the packaging by the side handles.

4.2 Installation

NOTICE

Condensate can damage the electronics.

A large difference in temperature between the storage location and the installation site can lead to the formation of condensate.

⇒ After receipt or storage, allow your vacuum device to acclimatize for at least 3–4 hours before putting it into operation.

Checking the installation conditions

Verifying the installation conditions

- The device is acclimatized.
- The ambient conditions are met and lie within the limitations of use.
- The pump must have a stable and secure base without additional mechanical contact apart from the pump feet.

Installing the vacuum pump

-> Example
Sketch of minimum
distances in labora-
tory furniture

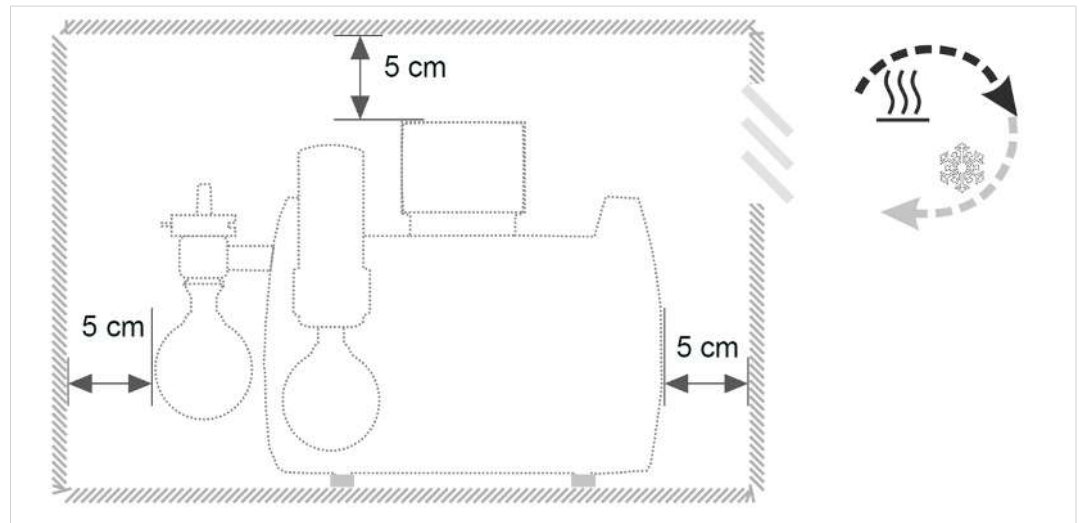

- ⇒ Place the vacuum pump on a stable, vibration-free, level surface.
- ⇒ When installing into laboratory furniture, maintain the minimum distance of 5 cm (2 in.) to adjacent objects or surfaces.
- ⇒ Avoid heat accumulation and ensure sufficient air circulation, especially in closed housings.

Observing the limitations of use

Ambient conditions

Ambient conditions		(US)
Ambient temperature	10 – 40°C	50 – 104°F
Installation height, max.	2,000 m above sea level	6562 ft above sea level
Humidity	30–85%, non-condensing	
Degree of contamination	2	
Impact energy	5 J	
Protection class (IEC 60529)	IP 40	
Protection class (UL 50E)	Type 1	
Avoid condensate or contamination from dust, liquids, and corrosive gases.		

- ⇒ Note the indicated IP protection rating. The IP protection is only guaranteed if the device is properly installed and connected.
- ⇒ When connecting the device, always take note of the specifications from the rating plate and in the chapter technical data.

4.3 Holding base controller





The holding base, controller, screw fasteners and vacuum sensor are enclosed in a separate box.

Before installation, you can mount the holding base on the pumping unit, attach the controller in it and connect the VACUU·BUS cable; see the following assembly description.

Instead of attaching the controller on the pumping unit, you can also attach it directly in the laboratory furniture with an appropriate gap; then use a VACUU·BUS extension cable for the connection.

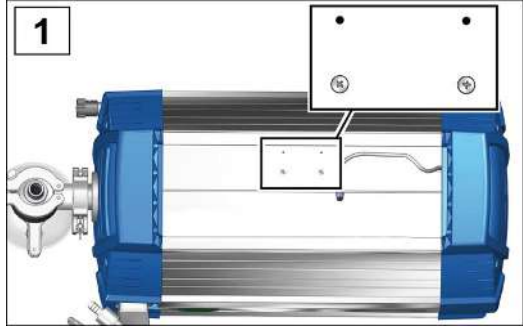
Mounting the holding base

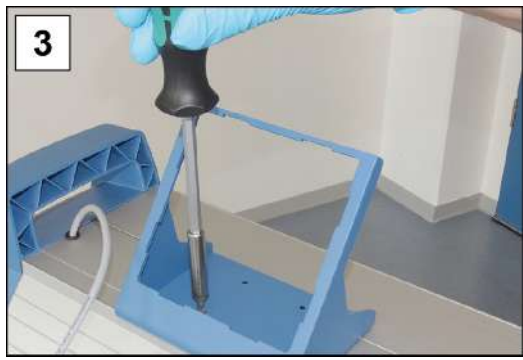
Mounting the holding base on the pumping unit (option)

 <p>1</p>	 <p>2</p>
<p>1. Unscrew the fittings from the pumping unit; Phillips-head screwdriver size 1.</p>	<p>2. Position the holding base on the pumping unit.</p>
 <p>3</p>	 <p>4</p>
<p>3. Screw in the fittings with the holding base.</p>	<p>4. Slide the controller into the holding base.</p>



5. Plug the VACUU·BUS cable into the power connector on the back side of the controller.

6. Also plug in the VACUU·BUS cable of peripheral devices, such as a vacuum sensor. Use Y-adapters (see accessories) if there are not enough connections.

4.4 Connection (supply connections)

On the pumping unit, supply connections are provided for vacuum and exhaust, and optionally for gas ballast, ventilation and coolant. Set up the connection for your pumping unit as described in the following examples. Also attach the provided connections and glass flasks to the condensers.

4.4.1 Vacuum connection (IN)



CAUTION

Flexible vacuum hoses can contract during evacuation.

Non-fixed, connected components may cause injury or do damage due to the jerky movement (shrinking) of the flexible vacuum hose. The vacuum hose can come loose.

- Fasten the vacuum hose to the connections.
- Fasten connected components.
- Measure the flexible vacuum hose so that the maximum shrinkage, i.e. the contraction, is taken into account.

NOTICE

Foreign bodies in the suction line can damage the vacuum pump.

⇒ Prevent particles, liquids or contaminants from being drawn in or from being able to flow back.

Connecting the vacuum hose

-> Example
Vacuum connection
at inlet IN

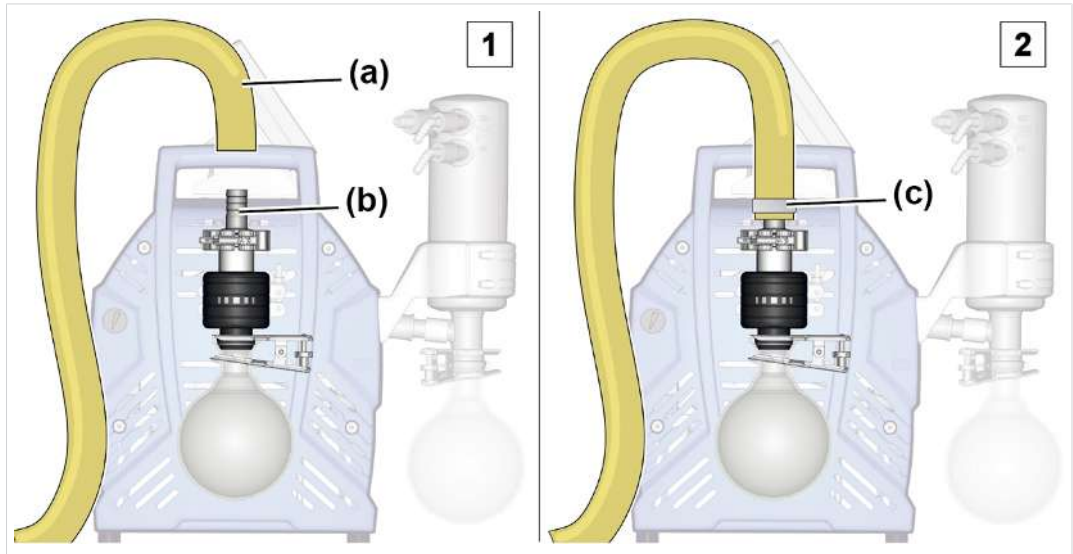

1. Take a vacuum hose **(a)** that fits onto the SW15 hose nozzle **(b)**.
2. Slide the vacuum hose **(a)** onto the hose nozzle and fasten the vacuum hose, e.g. with a hose clamp **(c)**. Alternatively, you can directly connect a metal hose with small flange KF25; see → **Order data on page 88**.



You will achieve the optimal vacuum for your application if you observe the following points:

- ⇒ Connect the shortest possible vacuum line with the maximum possible cross-section.
- ⇒ Use a vacuum hose with sufficient stability that is designed for the vacuum range used.
- ⇒ Connect hose lines so they are gas tight.

4.4.2 Outlet connection (OUT)



WARNING

Risk of rupture from overpressure in the discharge line.

Inadmissibly high pressure in the outlet line can cause the vacuum pump to burst or damage seals.

- The outlet line (outlet, gas outlet) must always be clear and non-pressurized.
- Always lay the outlet hose in a descending direction, or take measures to prevent condensate return into the vacuum pump.
- Observe the maximum admissible pressures and pressure differences.

Connect the outlet hose

→ Example
Outlet connection at
outlet EX

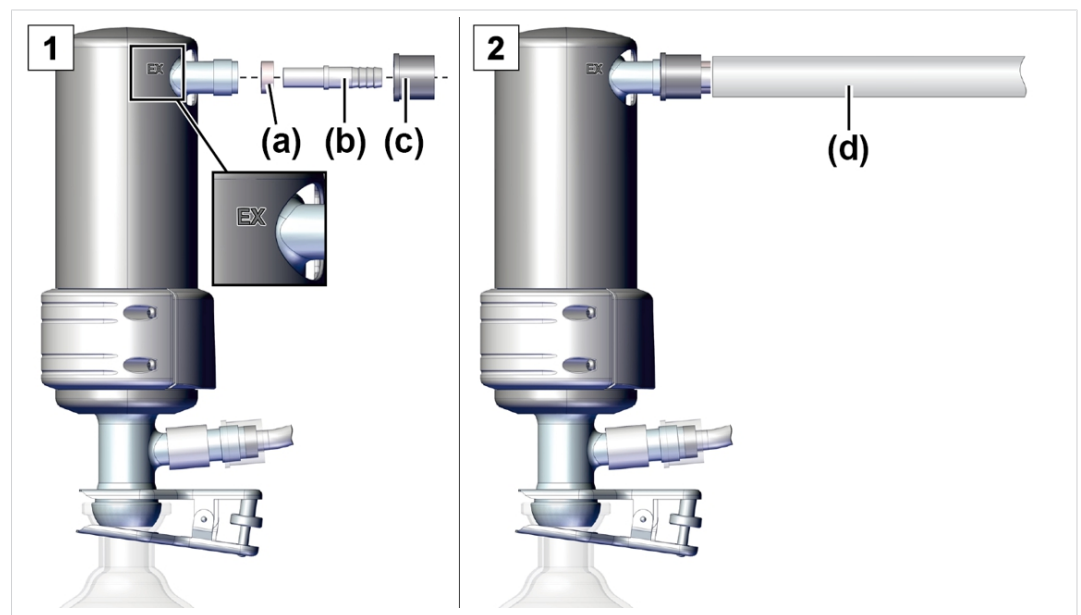

1. Connect rubber sealing ring **(a)**, hose nozzle **(b)** and union nut **(c)** as shown and screw them onto the connection.
2. Push outlet hose **(d)** onto the hose nozzle and, if necessary, lay the hose in a fume hood. If necessary, secure the outlet hose (e.g., with a hose clip).

4.4.3 Coolant connection on the emission condenser

Glass coolers and coolants

An emission condenser EK has one connection for coolants. Water or liquid in the circuit of a recirculating chiller, for example, is suitable for cooling.

The discharge-side emission condenser enables efficient outlet-side condensation of the vapors being pumped.

- Against condensate return
- Controlled condensate collection
- Nearly 100% solvent recovery

The insulating jacket protects against glass splinters in the event of breakage, provides thermal insulation against condensation, and forms an external impact protection.

The glass cooler is designed for a coolant pressure of 6 bar (87 psi) absolute. However, the strength of glass equipment depends on many factors:

- Surface defects (e.g., microcracks) increase during use.
- Tensile stress can be caused by temperature control, exothermic reactions, autoclaving, connecting elements and fasteners (e.g., ground glass joint clips) as well as by overpressure and underpressure.

VACUUBRAND does not guarantee the strength of the glass coolers.

VACUUBRAND accepts no liability for damage caused by coolants resulting from the use of the cooler.

**DANGER****Leakage of hazardous substances from a defective cooler.**

If the cooler is defective, hazardous or toxic substances that have been extracted may be released into the ambient air. The coolant may react with the condensed liquid in the collecting flask.

- Please observe the safety regulations for handling hazardous materials and media.
- Ensure that damage to the cooler cannot lead to a dangerous situation (e.g., by operating the pump in a fume hood).
- Regularly check glass components for cracks and damage. Do not use damaged coolers, and replace defective components immediately.

**CAUTION****Condensation can damage electrical components.**

The humidity in the ambient air can condense on cold coolant pipes and drip off.

- Always lay coolant lines so that no condensation can drip onto the pump or electrical components such as cables, electronics, or sockets.

**CAUTION****Impermissible overpressure in the coolant circuit can damage the emission condenser.**

The emission condenser can be damaged by excess pressure. Coolant hoses may come loose. Coolant may leak out.

- Observe the maximum permitted coolant pressure of 6 bar (87 psi) absolute at the emission condenser.
- Always ensure that the coolant can drain freely from the emission condenser (unpressurized).
- Prevent impermissible overpressure (for example, caused by blocked, kinked, or crushed coolant hoses) in the coolant circuit.
- Install any optional coolant valve exclusively on the inlet side of the emission condenser and never on the outlet side.
- Observe the maximum permissible pressure of other components connected to the coolant circuit (e.g., coolant valve).

NOTICE**Leaking coolant can damage the vacuum pump or the surrounding area.**

- ⇒ Use a pressure limiter for the coolant.
- ⇒ Use only a limited amount of coolant (e.g., by using a recirculating cooler).
- ⇒ Use a coolant monitor such as a water detector or water monitor (Aquastop).

Connect coolant

→ Example
Coolant connection
on EK

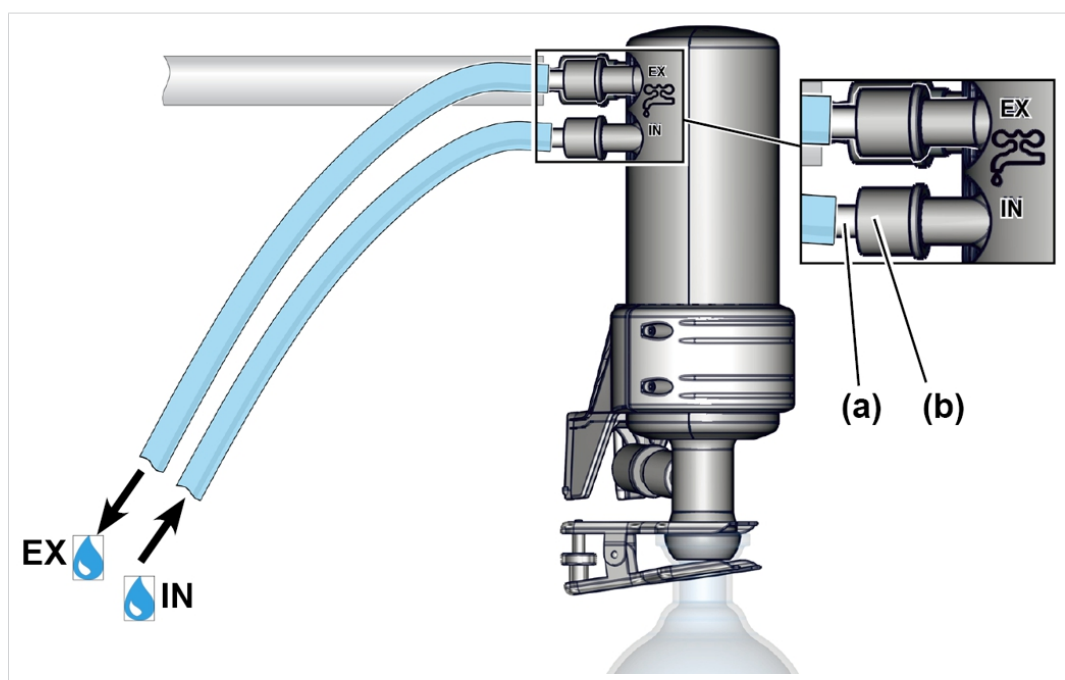

1. Remove the two curved hose nozzles from the round bottom flask.
 2. Fasten both hose nozzles **(a)** with the union nuts **(b)** to the condenser as illustrated.
 3. Attach the DN 6 to DN 8 hoses for the coolant to the condenser as shown in the illustration:
IN = Inlet
EX = Outlet
 4. Secure the hoses (e.g., using hose clips) to prevent them from unintentionally coming loose.
 - Coolant hoses connected.
- ⇒ Check the hose connections before each use and regularly during operation.

NOTICE Permissible range of coolant temperature at the emission condenser: -15°C to $+20^{\circ}\text{C}$.



As an alternative to liquid-cooled glass coolers, VACUUBRAND offers a water-free, electrically operated Peltier cooler.

⇒ Please contact our customer service if necessary.

4.4.4 Venting connection



DANGER

Explosion risk due to venting with air.

Depending on the process, a potentially explosive mixture can form during venting, or other dangerous situations can occur.

- Never vent processes with air in which a potentially explosive mixture can form.
- When flammable substances are present, use only inert gas for venting, e.g. nitrogen (max. 1.2 bar/900 Torr abs.).

VACUU-SELECT® sensor with venting valve

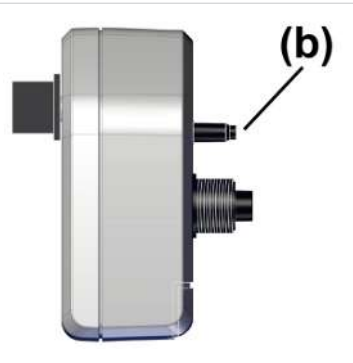

Venting connection (b) for a **VACUU-SELECT® Sensor** is described below.

Alternatively you can use a larger valve, e.g., a **VB M-B** (#20674217), for faster venting.

Vent with ambient air⁵

Position of venting connection

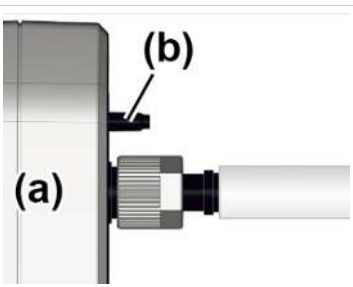

For venting (b) with ambient air, nothing needs to be connected to sensor (a).

⁵ Only applicable to sensors with an integrated venting valve.

Vent⁶ with inert gas – connect venting valve

Required connection material: Hose for hose nozzle, e.g., silicone tube 4/5 mm.

Venting valve inert
gas connection

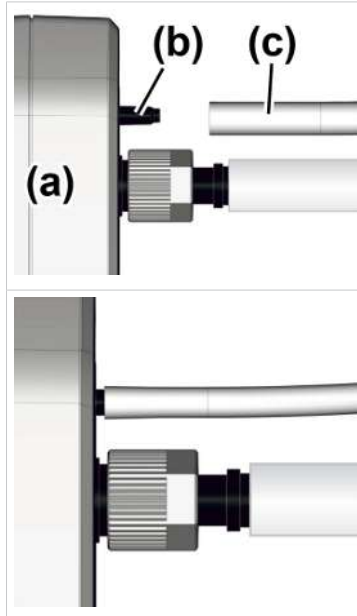

⇒ Push hose **(c)** onto the connection of venting valve **(b)** and connect inert gas (max. 1.2 bar/900 Torr, abs.).

☑ Venting valve with hose for venting with inert gas.

4.4.5 Gas ballast GB

Use of ambient air as gas ballast



DANGER

Explosion risk due to air as gas ballast.

By using air as a gas ballast, a small amount of oxygen enters the inside of the vacuum pump. Depending on the process, a potentially explosive mixture can form due to oxygen in the air, or other dangerous situations can occur.

- In the presence of flammable substances and for processes in which a potentially explosive mixture can occur, use only inert gas as a gas ballast, e.g. nitrogen (max. 1.2 bar/900 Torr abs.).

⁶ Avoid overpressure.

Gas ballast valve position

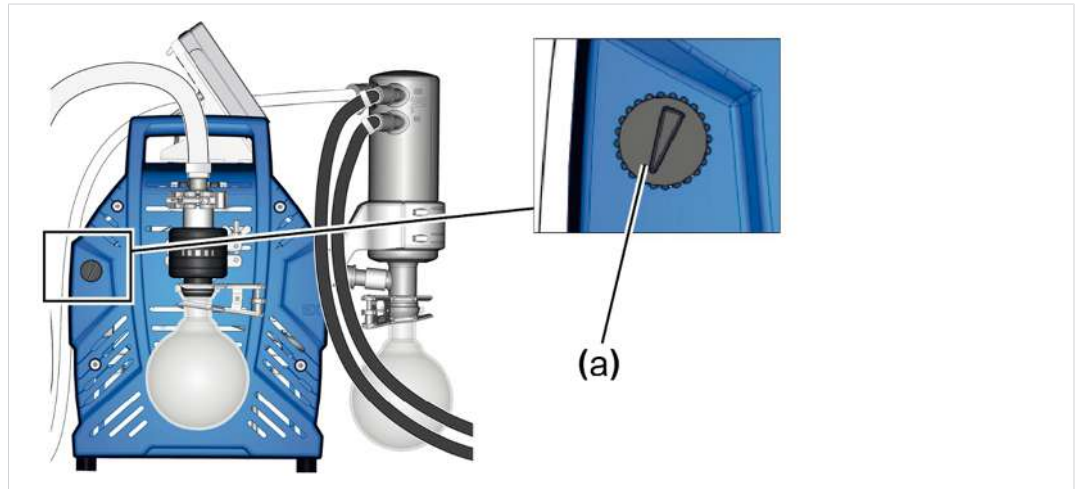

If ambient air is to be used as gas ballast, nothing needs to be connected at the pumping unit; gas ballast valve **(a)**; see also chapter: → **Operation with gas ballast on page 47**

Use of inert gas as gas ballast – OPTION

Prepare the inert gas connection (GB)

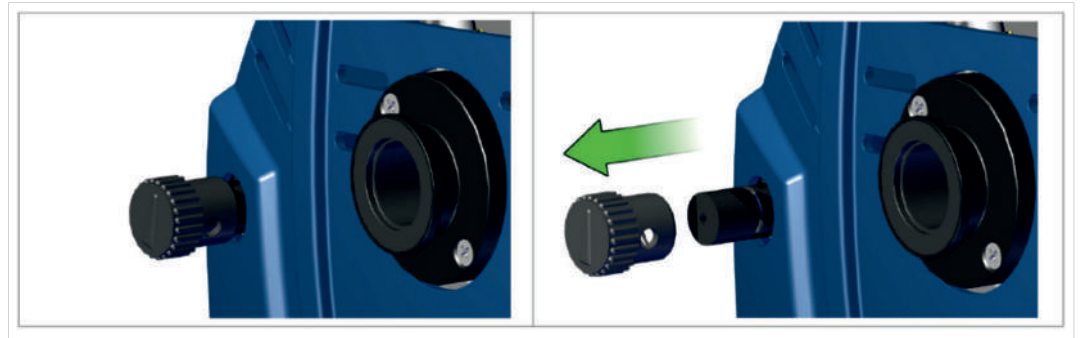

⇒ Remove the black gas ballast cap and connect a gas ballast adapter in its place.



On request, we can send you connection options and adapters for hose nozzles or small flanges.

4.5 Electrical connection

Connecting the pumping unit to the electrical system

-> Example
Electrical connection
of the pumping unit

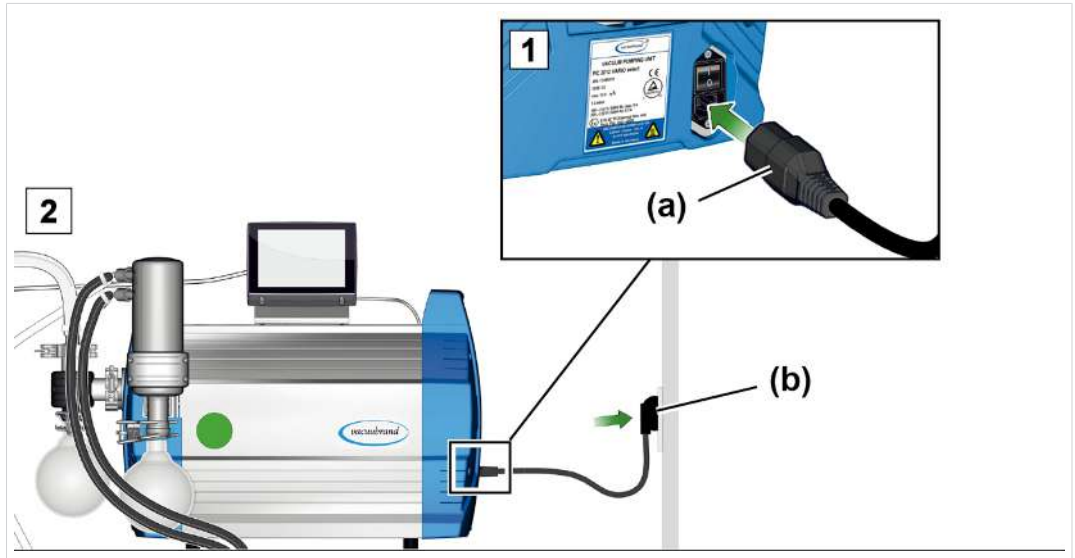

1. Plug the socket **(a)** of the power cable into the power connection of the vacuum pump.
2. Connect the power plug **(b)** to the power outlet.
 - Pumping unit connected to the electrical system.

NOTICE Lay the power cable so that it cannot be damaged by sharp edges, chemicals or hot surfaces.

Power connections with country code

-> Example
Power plug types

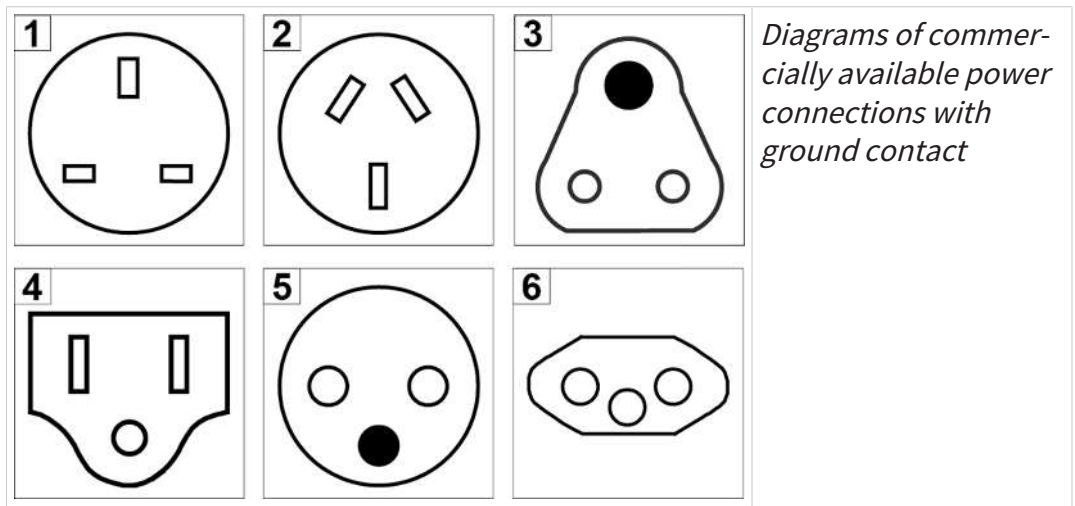

Diagrams of commercially available power connections with ground contact

1 UK	2 CN	3 IND
4 US	5 CEE	6 CH

The vacuum pump is delivered ready for use with the appropriate power plug.

NOTICE

- ⇒ Use the power plug which fits your power connection.
- ⇒ Do not use multi-outlet power strips connected in series as the power connection.
- ⇒ The power plug also serves as a disconnecter. Install the unit so that the plug can be easily disconnected from it.

Connection options for vacuum accessories

The VACUU·BUS interface is used as the power supply and control line for vacuum accessories.

1. Connect your accessories to your controller via the VACUU·BUS cable.
2. If necessary, extend the range and connection scope using suitable Y adapters and extension cables.

-> Example
Schematic diagram
of controller with
connected valve and
sensors

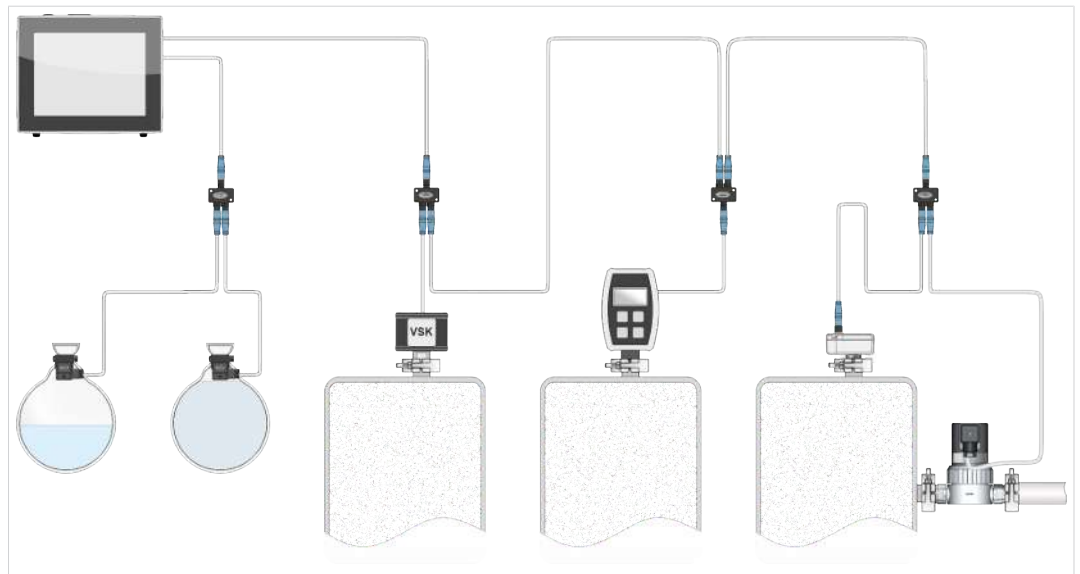

Accessories -> see Chapter Order data

5 Operation

Before putting into operation, make sure that the activities described in the chapter **Installation and power connection** have been carried out properly.

With the exception of the chapter Switching on and off, this instruction manual contains descriptions about the mechanics of a PC 301x NT VARIO select series pumping unit.

The operation of an installed vacuum regulator ⁷ and its functions are described in the instruction manual of a **VACUU·SELECT**.

5.1 Switching on

Switching on the pumping unit

Switching on



1. Switch on the rocker switch **(a)** – switch position **I**.
2. Press the ON/OFF button **(b)** on the controller.
 - Display with start screen.
 - After approx. 30 seconds, the process display appears with the control elements in the display of the controller.

⁷ WEB: <https://www.vacuubrand.com/controller>

5.2 Operation with controller

5.2.1 Operator interface

Operator interface

VACUU·SELECT® with process display

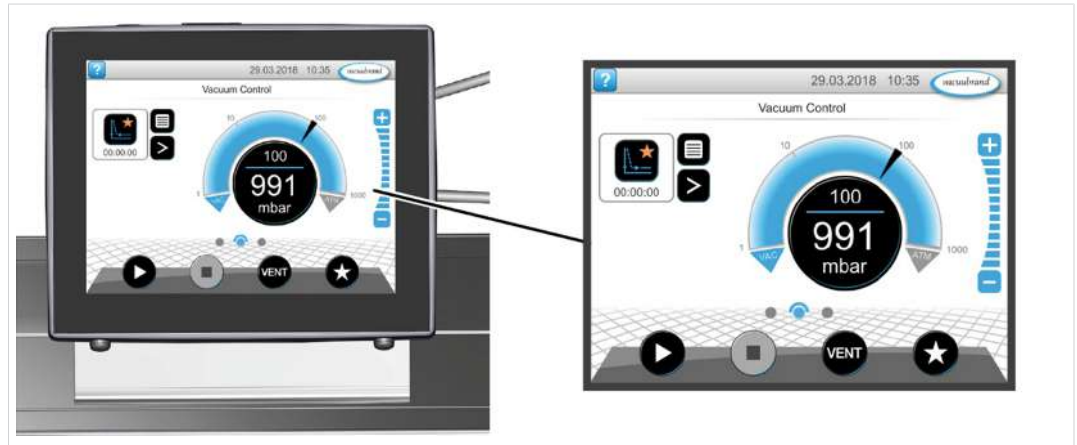

Process display



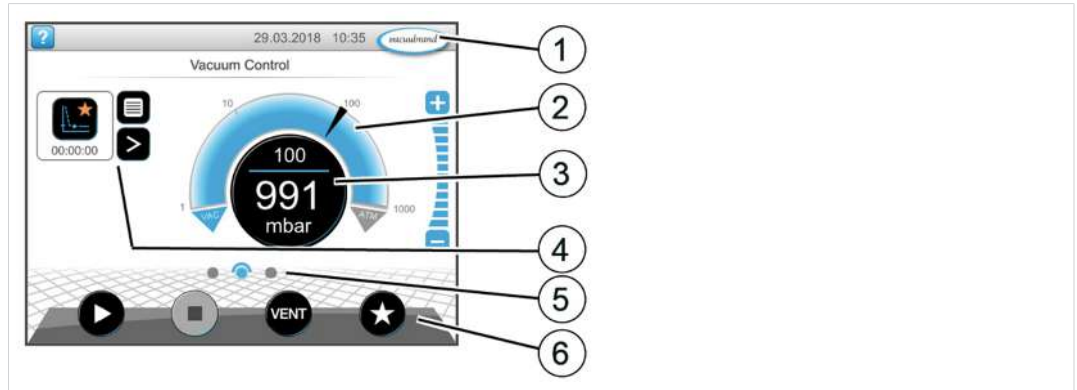





Pressure display for a process



- 1 Status bar
- 2 Analog pressure display – pressure curve
- 3 Digital pressure display – pressure value (target value, actual value, pressure unit)
- 4 Process display with context functions
- 5 Screen navigation
- 6 Controls for the controller

Controls

Operating elements
vacuum controller

Button	Function
 	<p>Start Start application – available only on the process screen.</p>
 	<p>Stop op application – always possible.</p>
	<p>VENT⁸ – Vent the system (option) Press button < 2 s = vent briefly; control continues.</p>
 	<p>Press button > 2 s = vent to atmospheric pressure; vacuum pump is stopped. Press button during venting = venting is stopped.</p>
 	<p>Favorites View Favorites menu.</p>

⁸ The VENT button is only shown if a venting valve is connected or activated.

5.2.2 Operation

Starting the vacuum controller

Start

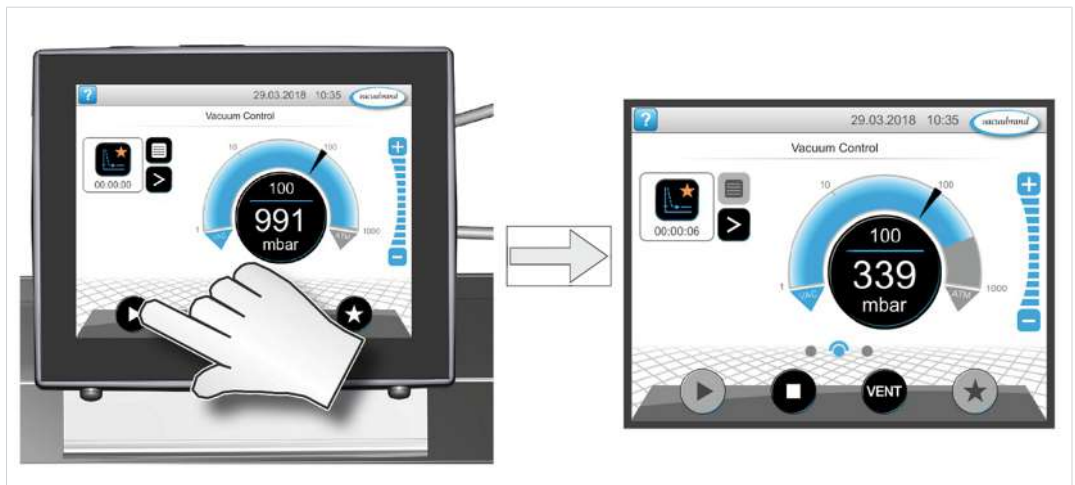

Stopping the vacuum controller

Stop

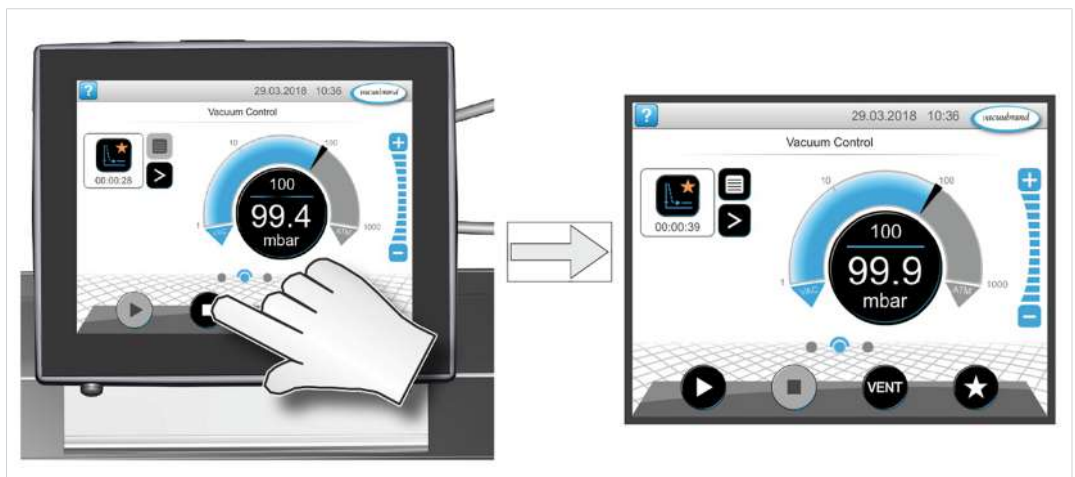

Venting

Venting

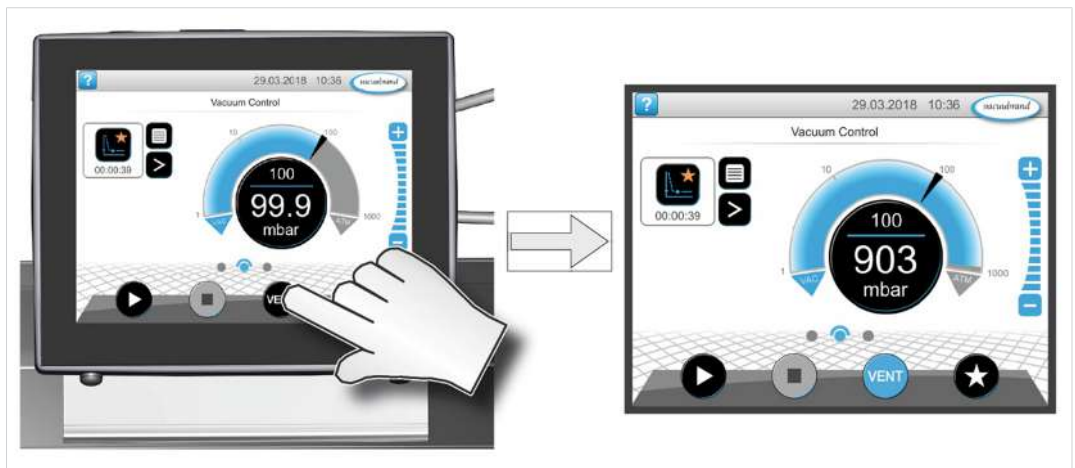

5.2.3 Operation with gas ballast

Meaning The supply from the gas ballast (= gas addition) ensures that vapors are not condensed in the vacuum pump; instead, they are emitted out of the pump. This allows greater amounts of condensable vapors to be pumped, which extends the service life. The ultimate vacuum with gas ballast is slightly higher.

Opening/closing the gas ballast valve

Operating the gas ballast valve

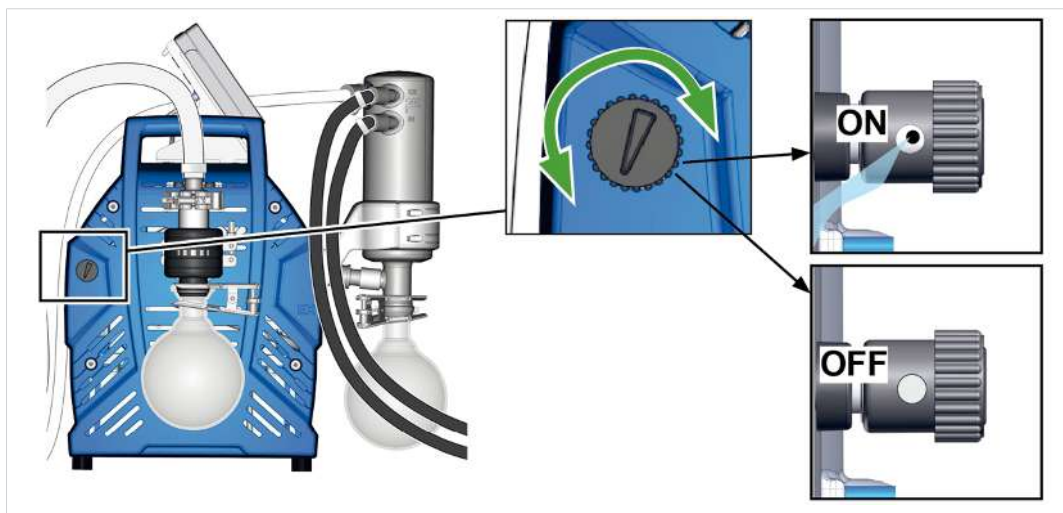

- ⇒ Turn the black gas ballast cap in any direction to open or close the gas ballast valve.
- ⇒ If possible, only evacuate the condensable vapors, e.g. water vapor, solvents, etc., when the vacuum pump is at operating temperature and the gas ballast valve is open.
- ⇒ Connect inert gas as the gas ballast in order to prevent and exclude the formation of potentially explosive mixtures during operation.
- ⇒ Comply with the max. permitted pressure of 1.2 bar/900 Torr abs. at the gas ballast connection.



If the gas volume in the vacuum pump is low, gas ballast can be dispensed with in these cases to increase the solvent recovery rate.

5.3 Switching off (decommissioning)

Switching off the pumping unit

Switching off, e.g. taking the pumping unit out of operation

1. Stop the process and allow the pumping unit to continue running for approx. 30 minutes with open gas ballast or open inlet (IN).
 - Condensate and residual media are rinsed out of the vacuum pump.

NOTICE Avoid deposits and rinse the condensate out of the pump.

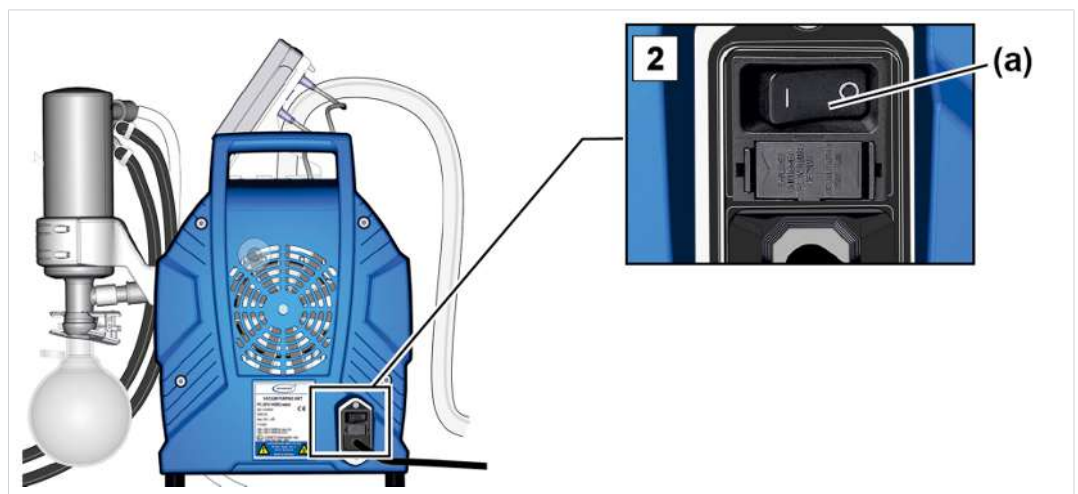

2. Switch off the rocker switch **(a)** – switch position 0.
 - Pumping unit switched off.
3. Disconnect the power plug.
4. Disconnect the pumping unit from the equipment.
5. Empty the glass flasks.
6. Check the pumping unit for any damage and soiling.

5.4 Storage

Store the pumping unit

1. Clean the pumping unit if required.
2. Recommendation: Perform preventative maintenance before storing the pumping unit. Especially if it ran more than 15,000 operating hours.
3. Close the inlet and outlet ports (e.g., with the transport caps).
4. Package the pumping unit such that it is protected from dust; enclose desiccant if necessary.
5. Store the pumping unit in a cool, dry location.

NOTICE If damaged parts are stored for operational reasons, these should be clearly identified as not operational.

6 Troubleshooting

6.1 Technical assistance

For troubleshooting, refer to table → **Error – cause – remedy on page 50.**

For technical assistance or in the event of an error, please contact our **Service** department.



The device should only be operated in perfect technical condition.

- ⇒ Adhere to the recommended maintenance intervals to ensure a properly functioning system.
- ⇒ Send defective devices to our Service department or your specialist retailer for repairs.

6.2 Error – cause – remedy

Error	Cause	Remedy	Personnel
Readings deviate from the reference standard	Vacuum sensor dirty. Moisture in the sensor. Sensor defective. Sensor measures incorrectly.	Clean sensor measuring chamber. Allow sensor measuring chamber to dry (e.g., by pumping down). Calibrate sensor with reference gage. Replace defective components.	Qualified employee
Sensor does not pass on measured value	No voltage applied. VACUU·BUS plug-in connection or cables defective or not connected.	Check VACUU·BUS plug-in connection and cables to the controller.	Operator
Sensor does not pass on measured value	Sensor defective.	Replace defective components.	Qualified employee
Venting valve does not operate	No voltage applied. VACUU·BUS plug-in connection or cables defective or not connected. Venting valve dirty.	Check VACUU·BUS plug-in connection and cables to the controller. Clean venting valve. If necessary, use a different, external venting valve.	Operator

Error	Cause	Remedy	Personnel
Venting valve does not operate	Venting valve in sensor defective.	Replace defective components.	Qualified employee
No or little suction power	Leak in the suction line or in the apparatus. Round bottom flasks not mounted properly. Condensate inside the vacuum pump. Gas ballast open. Gas ballast cap porous or no longer present. Vacuum line too long or cross-section too small.	Check suction line and apparatus for possible leaks. Check the round bottom flask and fit it correctly. Check apparatus for leaks. Allow vacuum pump to run for a few minutes with the suction nozzle open. Close gas ballast. Check gas ballast cap. Replace defective gas ballast cap. Use shorter vacuum lines with a larger cross-section.	Operator
No or little suction power	Deposits inside the vacuum pump. Diaphragms or valves defective. High level of vapor generated in the process.	Clean and check pump heads. Replace diaphragms and valves. Check process parameters.	Qualified employee
No display	Pumping unit switched off. Power plug not correctly plugged in or pulled out. VACUU·BUS plug connection or cabling not plugged in. Controller switched off.	Switch on Pumping unit. Check mains connection and mains cable. Check VACUU·BUS plug-in connection and cables to the controller. Switch on the controller.	Operator
No display	VACUU·BUS plug connection or cabling defective. Controller defective.	Check VACUU·BUS plug-in connection and cables to the controller. Replace defective components.	Qualified employee

Error	Cause	Remedy	Personnel
Condenser (chiller) defective	Mechanically damaged.	Send in.	Technician
Loud operating noises	Outlet line open. No hose installed. Glass flask on EK missing.	Check outlet line connections. Connect the outlet line to an extraction system or fume hood. Check hose and install it right. Assemble glass flask.	Operator
Loud operating noises	Torn diaphragm or loose diaphragm clamping disc.	Service the vacuum pump and replace defective parts or send in the device.	Qualified employee
Loud operating noises	Ball bearing defective.	Send in the device.	Technician
Vacuum pump does not start.	Pumping unit switched off. Power plug not correctly plugged in or pulled out. VACUU·BUS plug-in connection or cables defective or not connected. Overpressure in the outlet line.	Switch on Pumping unit. Check power connection and cable. Check VACUU·BUS plug-in connection and cables to the controller. Open the outlet line. Ensure a clear passage.	Operator
Vacuum pump stopped Vacuum pump does not start	Motor overloaded. Motor overheated. Thermal protection triggered.	Allow the motor to cool down. Reset the fault manually: Acknowledge the error message on the controller → Switch off the pump or pull out the mains plug → Determine and eliminate the cause of the fault → Allow the pump to cool down and switch it on again.	Qualified employee

Error	Cause	Remedy	Personnel
Measured leakage current too high	A frequency converter and a switched-mode power supply are installed in the pump.	Use a suitable measuring method/measuring device.	Qualified employee

7 Cleaning and maintenance



WARNING



Danger due to electrical voltage.

- Switch off the device before cleaning or maintenance.
- Disconnect the power plug from the power outlet.



WARNING

Danger due to contaminated components.

When pumping dangerous media, hazardous materials can adhere to interior pump components.

If this case applies to you:

- Wear your personal protective equipment (e.g., safety gloves, eye protection, and, if required, a respirator).
- Decontaminate the vacuum pump as far as possible before opening the vacuum pump. If required, have the vacuum pump decontaminated by an external service provider.
- Take safety precautions when handling hazardous materials, in accordance with your operating instructions.

NOTICE

Carrying out work in an improper manner may cause damage.

- ⇒ Have Maintenance tasks carried out by a qualified specialist or at least a trained person.
- ⇒ Before carrying out the first Maintenance, please read through all action instructions to obtain an overview of the service activities required.

7.1 Information on service activities

Recommended maintenance intervals ⁹

Maintenance intervals

Maintenance intervals	As required	15,000 h
Replace diaphragms		x
Replace valves		x
Replace O-rings		x
Clean or replace PTFE molded hose	x	
Replace pressure release valve on EK	x	
Clean pumping unit	x	

Recommended auxiliary equipment

->Example Recommended auxiliary equipment for cleaning and maintenance



Meaning

No.	Auxiliary equipment
1	Mat for round bottom flasks
2	Protective gloves
3	Chemical resistant container and funnel

⁹ Recommended maintenance interval according to hours of operation and under normal operating conditions; depending on the setting and field of application, we recommend carrying out cleaning and maintenance as needed.

Tools needed for maintenance

-> Example Tools



Meaning

No.	Tool	Size
1	Seal set Seal set PC 3010/PC 3012 NT VARIO select #20696839 <i>or</i> Seal set PC 3016 NT VARIO select #20696867	1x
2	Diaphragm wrench #20636554	SW66
3	Flat-nose pliers Closing hose clips	
4	Flat-head screwdriver Opening hose clips	Size 1
5	Phillips-head screwdriver Screw fasteners for controller holding base	Size 1
6	Torx screwdriver Screw fasteners for EK counterholder Fastening, loosening clamping brackets	TX10 TX20
7	Hexagon socket wrench Screw fasteners for side panel Screw fasteners for head cover Screw fasteners for PEC or EC bracket Screw fasteners for housing parts with handle Fastening, loosening side panel retaining plates	Size 5 Size 5 Size 4 Size 4 Size 4
8	Torque wrench, adjustable 2 –12 Nm	

7.2 Cleaning

This chapter does not describe how to decontaminate the product. Simple cleaning and care measures are described here.

⇒ Before cleaning, switch off the pumping unit.

	CAUTION
Risk of burning due to hot surfaces	
An elevated exhaust gas temperature can lead to hot surfaces on the instrument and on attached components (e.g., glass flasks). The temperatures generated during operation may cause burns.	
<ul style="list-style-type: none">➤ Use protection against accidental contact, especially when the exhaust temperature is persistently high.➤ Allow the instrument to cool before you empty the glass flask or begin performing maintenance tasks.➤ For tasks that must be performed during operation, use your personal protection equipment (e.g., heat-resistant safety gloves).	

7.2.1 Housing surface

Cleaning the surface



Clean soiled surfaces with a clean, slightly damp cloth. We recommend water or a mild soap solution to moisten the cloth.

7.2.2 Emptying the glass flask

Removing and emptying the glass flask

-> Example
Emptying the glass
flask

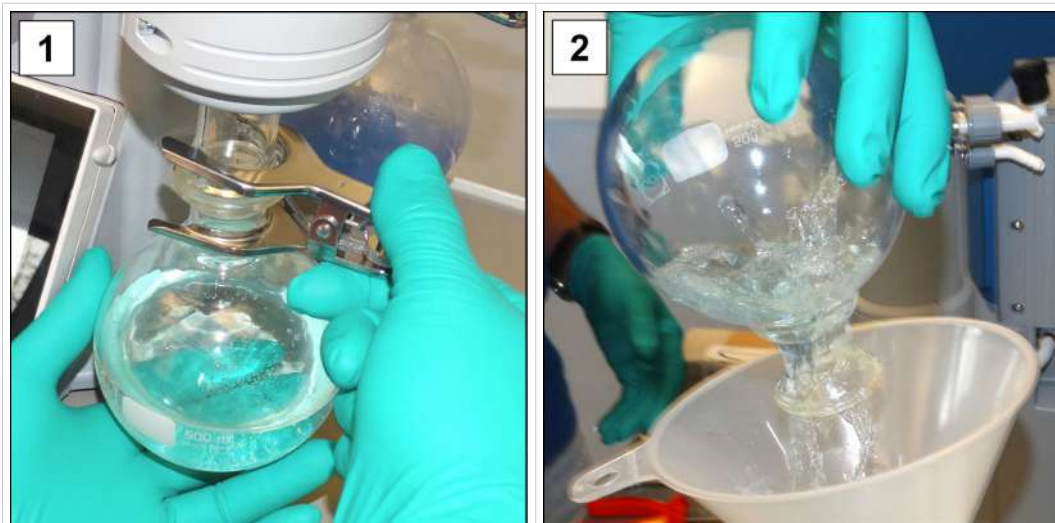

1. Open the joint clamp and remove the glass flask.
2. Empty the glass flask into a suitable container, e.g. a chemical-resistant canister.
3. Reattach the glass flask (separator) to the condenser with the joint clamp.



Depending on the application, the collected liquid can either be recycled or properly disposed of.

7.2.3 Cleaning or replacing PTFE molded hoses

Maintenance provides an opportunity to check the components of the pumping unit, including the hosing.

- ⇒ Clean the inside of highly soiled molded hoses, e.g. with a pipe cleaner or similar.
- ⇒ Replace cracked or defective molded hoses.

7.3 Vacuum pump maintenance

7.3.1 Maintenance items

Items to receive maintenance

-> Example
Maintenance of
pump heads

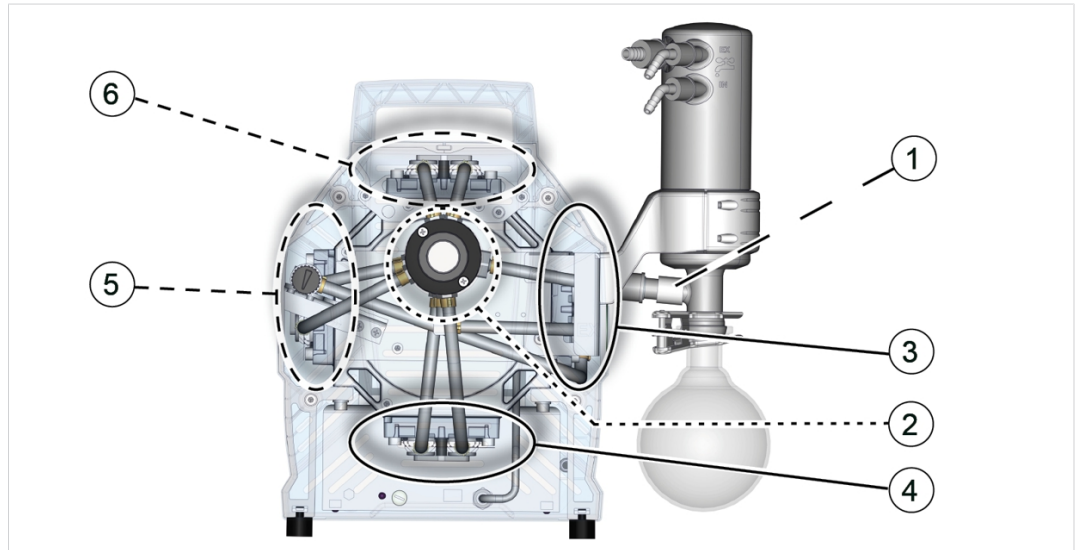

Meaning

Maintenance items and sequence

- 1 Silicone pressure release valve EC #20638821
- 2 Suction-pressure distributor (behind inlet separator)
- 3 Pump head pair, right
- 4 Pump head pair, bottom
- 5 Pump head pair, left
- 6 Pump head pair, top

7.3.2 Preparation

Dismantle controller and holding base, see chapter → ***Holding base controller on page 30***

Dismantling device and housing parts

-> Example
Prepare for maintenance



1. Switch off the pumping unit and disconnect the power plug.



2. Remove the glass flask and connected hoses from the inlet IN.



3. Remove the glass flask and connected hoses from the emission condenser EK.



4. Open the tension ring from the inlet separator.



5. Take the inlet separator off and set it aside.

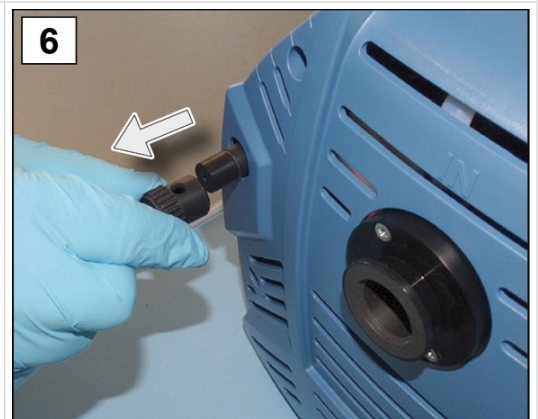

6. Pull the cap off the gas ballast.



7. Remove the four screws from the front housing section; hexagon socket wrench size 4.

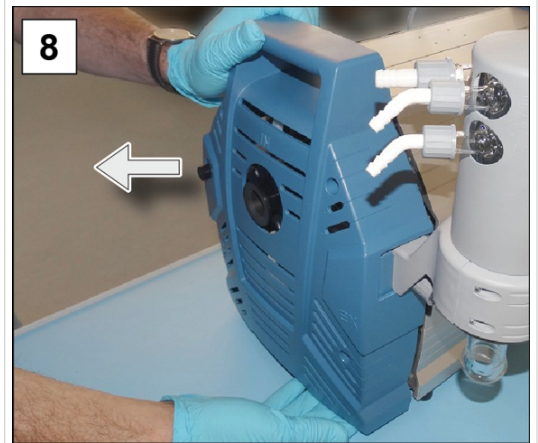

8. Take the housing section off and set it aside.

-> Example
Disassembling the EK

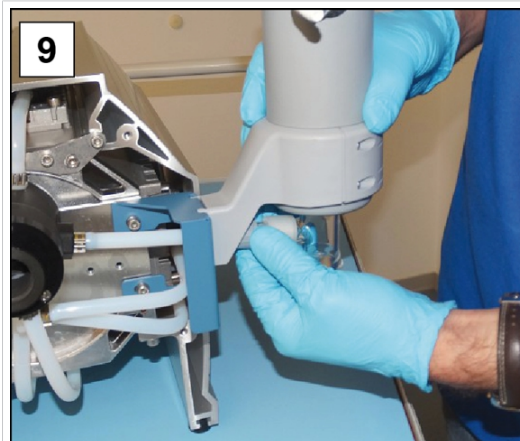

9. Open the union nut from the inflow EK.



10. Remove the two screws from the EK bracket; hexagon socket wrench size 4.

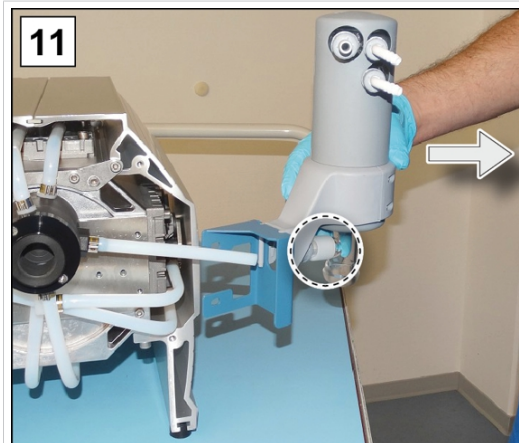

11. Pull the EK together with the bracket from the molded hose. Here you can check the pressure release valve of the EK and replace it in case of damage.



12. Put the cooler down safely so that no liquid can leak out.

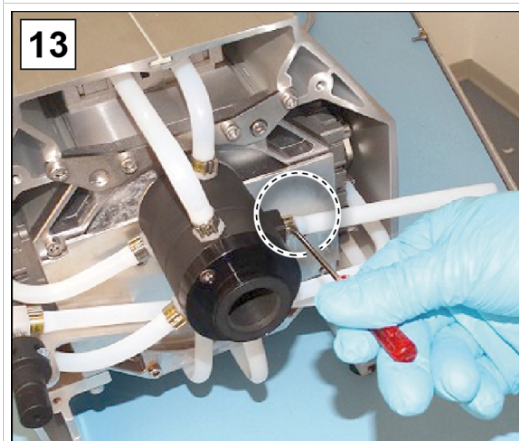

13. Open the hose clamp from the molded hose which leads to the EK; flat-head screwdriver size 1.

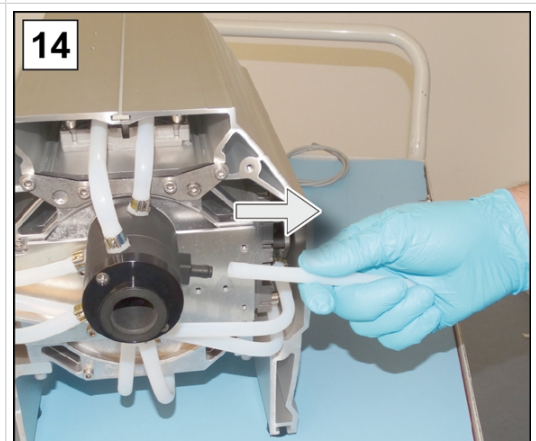

14. Pull the molded hose off.

7.3.3 Replacing the membrane and valves

Dismantling other housing parts

→ Example
Dismantling the
housing

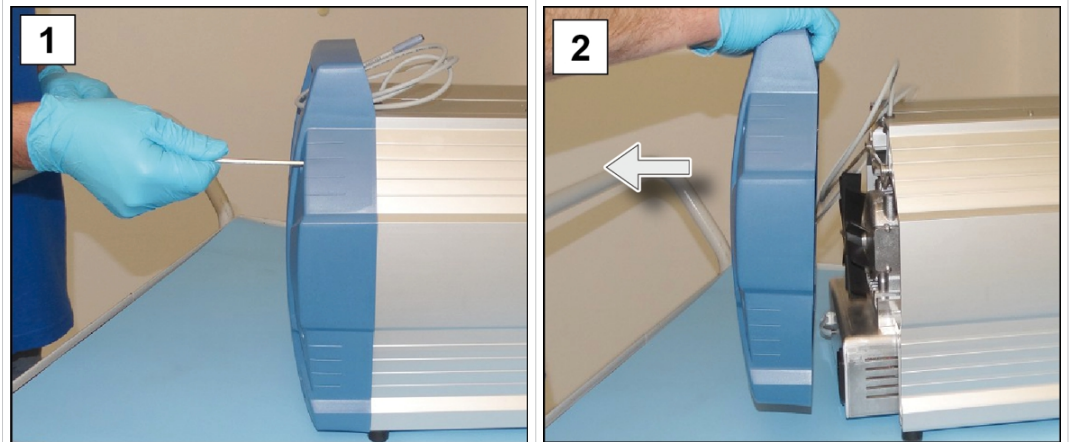

1. Remove the four screws from the rear housing section; hexagon socket wrench size 4.

2. Take the housing section off and set it aside.

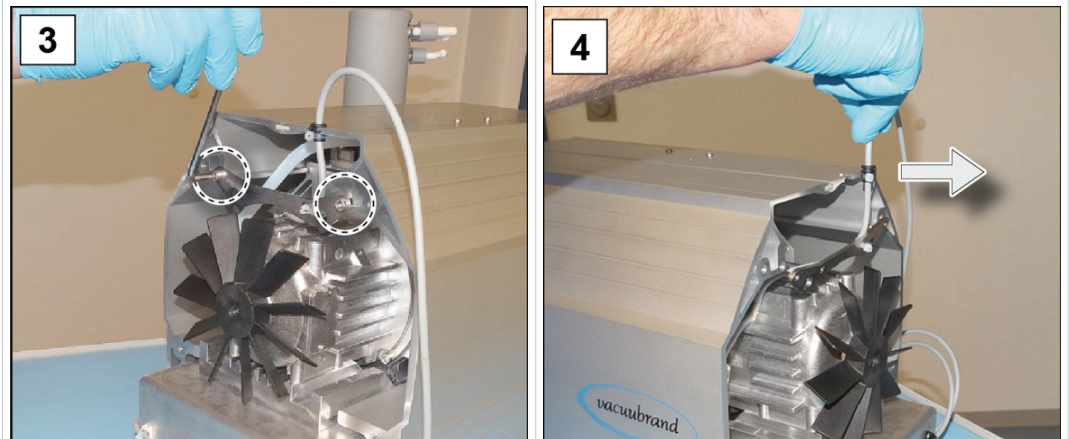

3. Remove the screws from the side panel retaining plate; hexagon socket wrench size 4.

4. Feed the cable out of the gap.

Removing the side panels

Removing the right-hand side panel (uncovering the first pump head pair)

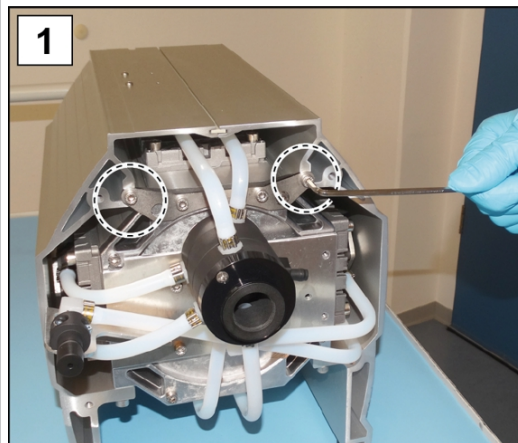

1. Remove the 2 outer screws from the retaining plate; hexagon socket wrench size 4.

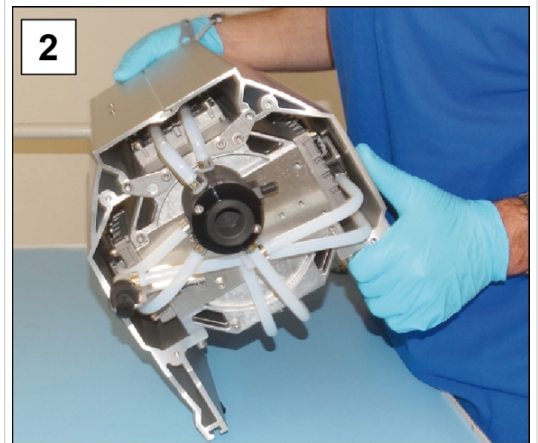

2. Carefully set the pump to the side.

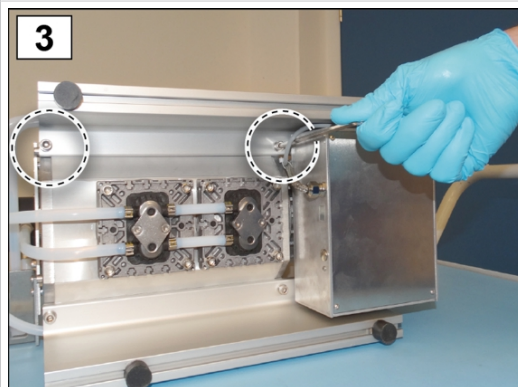

3. Unscrew the screw fasteners of the side panel; hexagon wrench size 5.

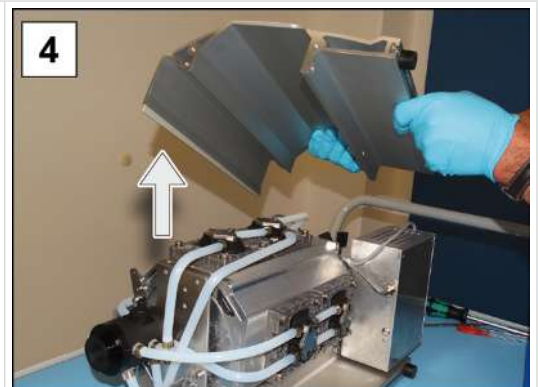

4. Lift the side panel from the pump. For the moment, the lower side panel remains attached for stabilization purposes.

Exploded-view drawing of pump head

-> Example
Explosion-view drawing of pump head pair

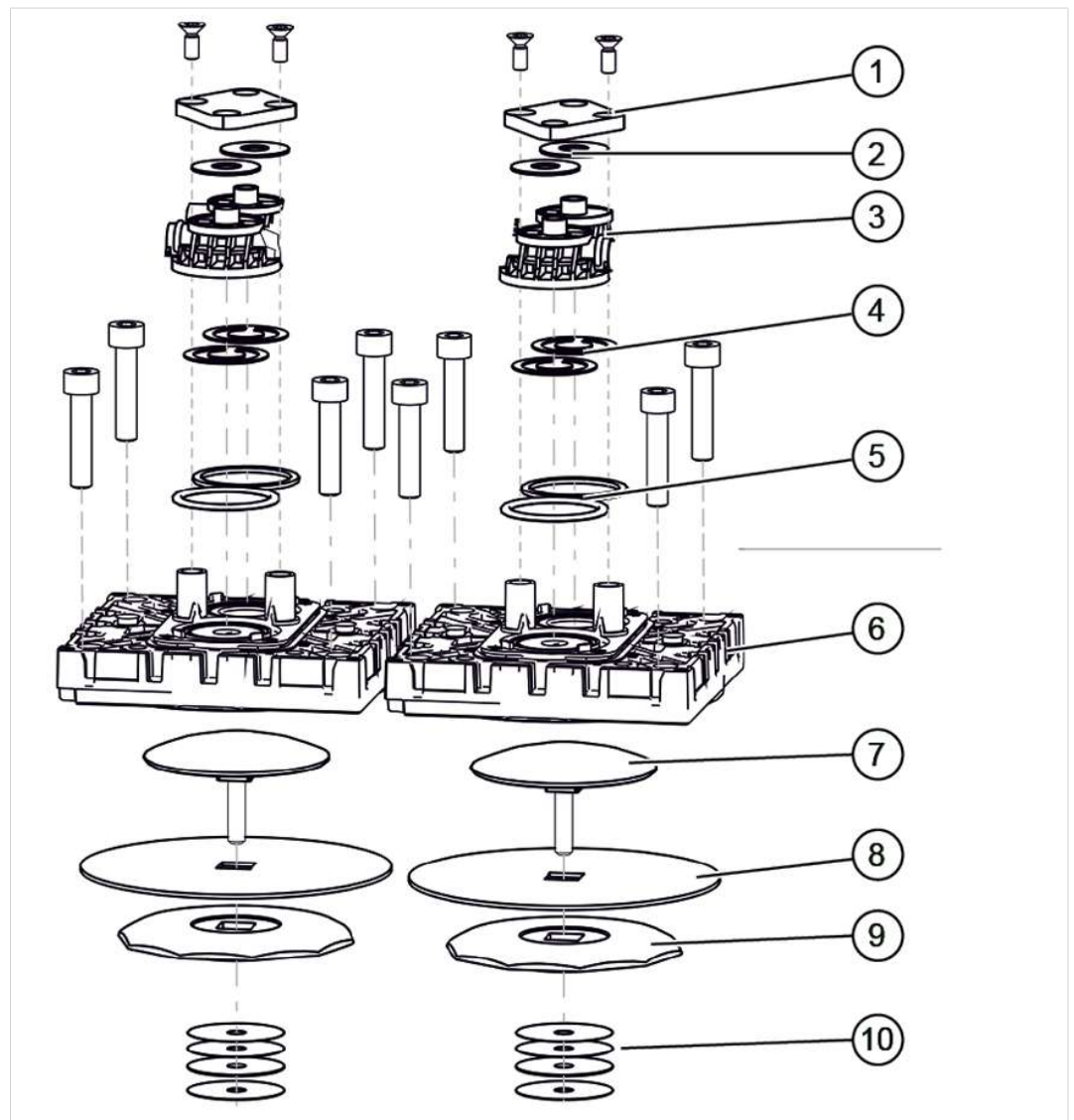

Meaning

Valve maintenance

- 1 Clamping bracket + screw fasteners
- 2 Cup springs
- 3 Valve clusters
- 4 Valves
- 5 O-rings Size 26 x 2

Membrane maintenance

- 6 Head cover + screw fasteners
- 7 Membrane spring washer with square head screw
- 8 Membrane
- 9 Membrane support disc
- 10 Spacers, max. 4 pieces per pump head

Pump head pair, right

-> Example
Maintenance of
pump head pair,
right-side

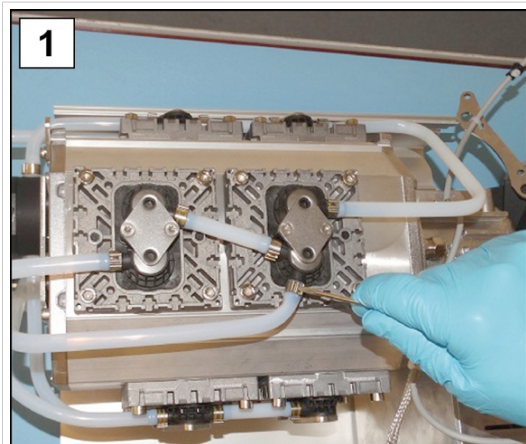

1. Open the hose clamps of the outer hoses. Flat-head screwdriver size 1.

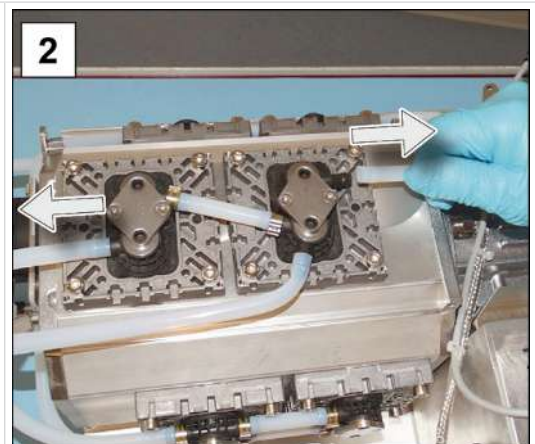

2. Pull the molded hoses off.



3. Unscrew the hexagon socket screws from the head covers. Hexagon socket wrench size 5.

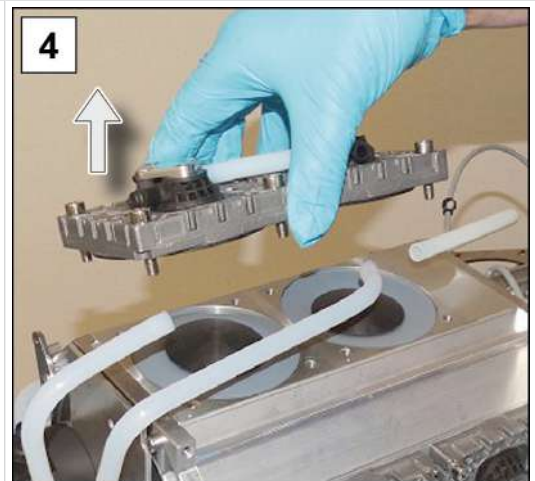

4. Remove the pump head pair with the screw fasteners.

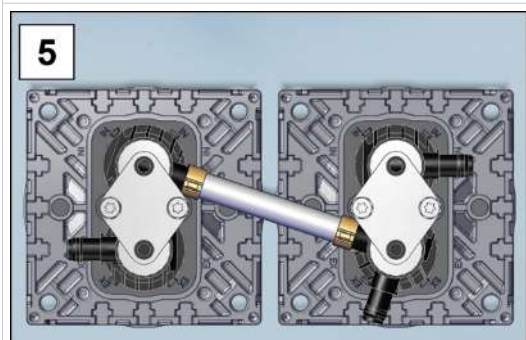

5. Set the pump head pair to the side.

Replacing membranes

-> Example
Membrane replacement

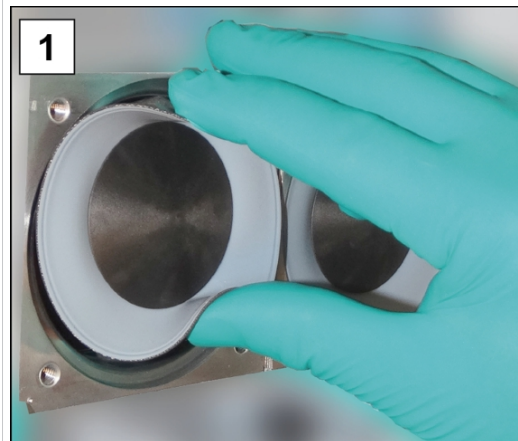

1. Fold the membrane in on the sides.



2. Carefully position the membrane wrench onto the membrane support disc and unscrew the assembly with the membrane wrench fixed in place.

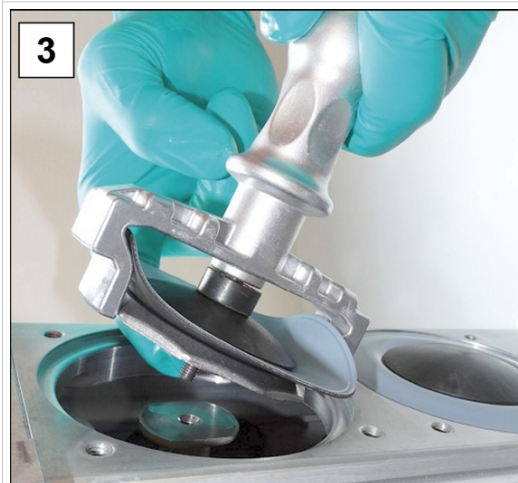

3. Lift the membrane with all its parts out of the vacuum pump. If spacers are stuck to the connecting rod, carefully remove these.

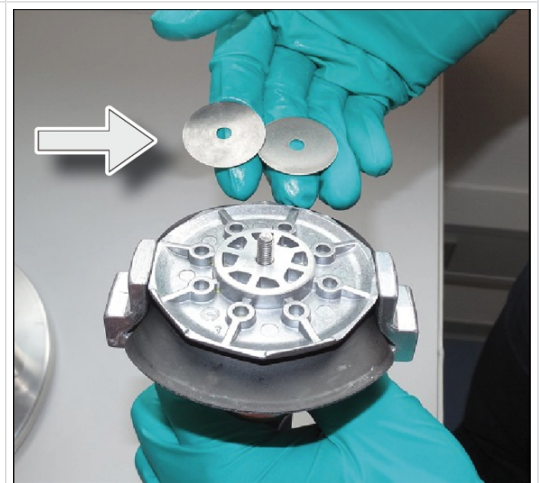

- Do not let any spacers fall into the aluminum housing.
- Make sure there are no spacers stuck to the connecting rod.
- Keep the spacers for later use. It is imperative that these are re-installed in the same quantity.

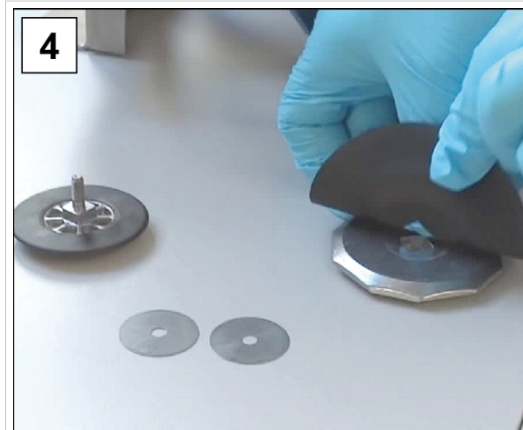

4. Pull the membrane spring washer out and remove the used membrane.



5. Place the new membrane onto the square bolt of the membrane spring washer.

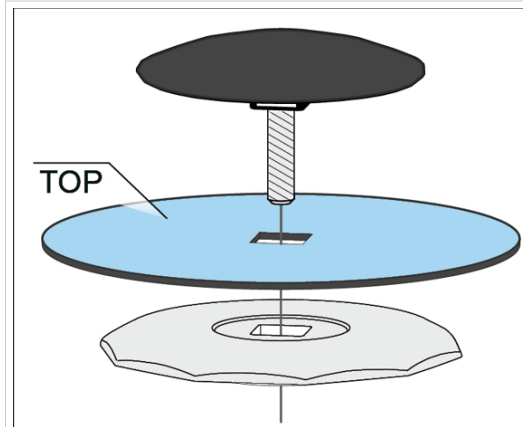

- Ensure that the diaphragm is installed correctly with the coated, light side facing the clamping disc.
- Pay special attention to correct positioning on the square head.



6. Place all spacers onto the threaded bolt.



7. Attach the membrane assembly to the membrane wrench.



8. Hold onto the spacers and carefully place all components into the threaded hole of the connecting rod.



9. Tighten the assembly by hand at first using the membrane wrench.



10. Then place a torque wrench with a hexagon socket bit onto the membrane wrench and tighten the assembly to 6 Nm.

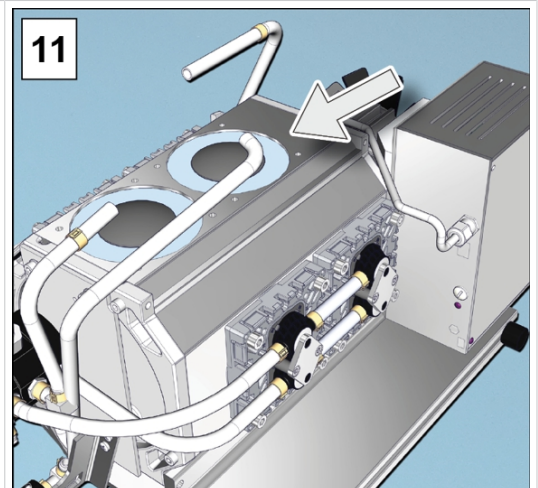

11. Repeat steps 1 to 10 to change the next membrane.

Replacing valves

→ Example
Valve replacement

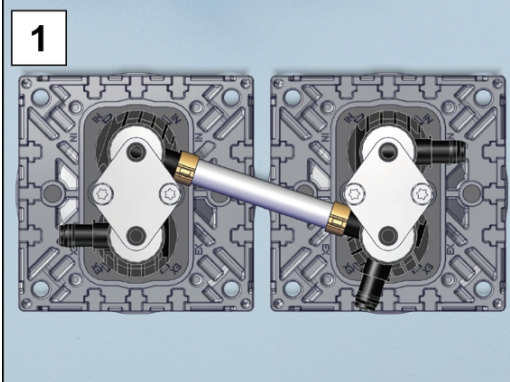
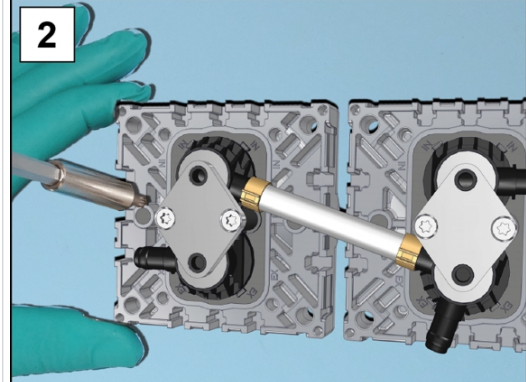
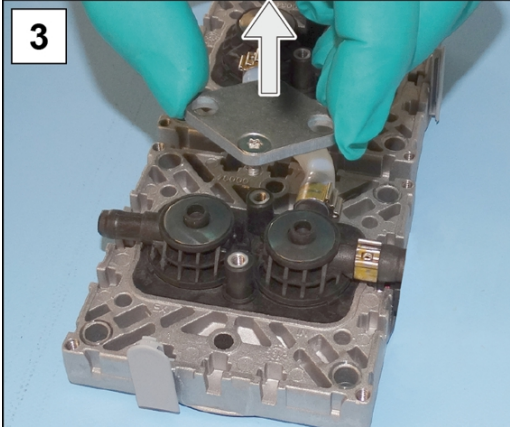
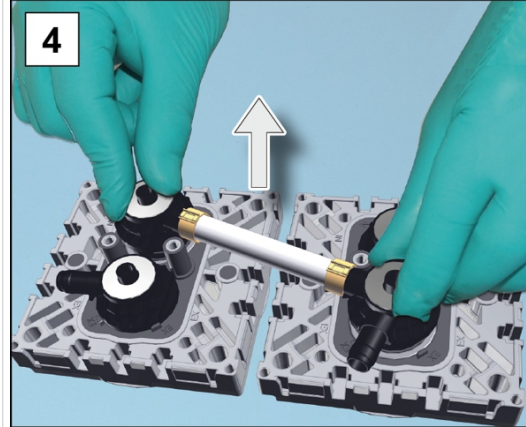
 <p>1</p>	 <p>2</p>
<p>1. Take the pump head pair that was set aside.</p>	<p>2. Unscrew the Torx screws. Torx screwdriver size Tx20.</p>
 <p>3</p>	 <p>4</p>
<p>3. Remove the clamping bracket from the valve clusters.</p>	<p>4. Remove the individual valve terminals and the valve terminals with the tubing together with the disk springs.</p>

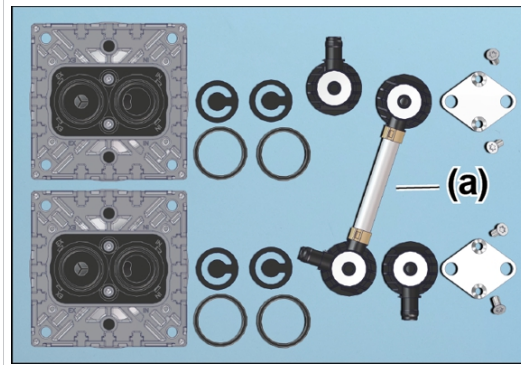

Plan view example:
Valve terminals, valves, O-rings,
molded hose of a pump head
pair.

- The quantity and interconnection of the molded hoses **(a)** depends on the position of the pump head pair. Pump head pairs may never be interchanged.
- Valves can stick to the underside of the valve cluster.
- Depending on the pump type, the valve material is either PTFE (white) or FFKM (black).

→ Example
Valve replacement

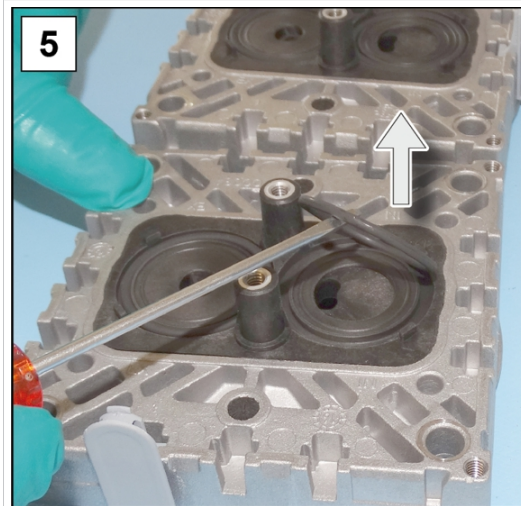

5. Carefully remove the used O-rings and valves.

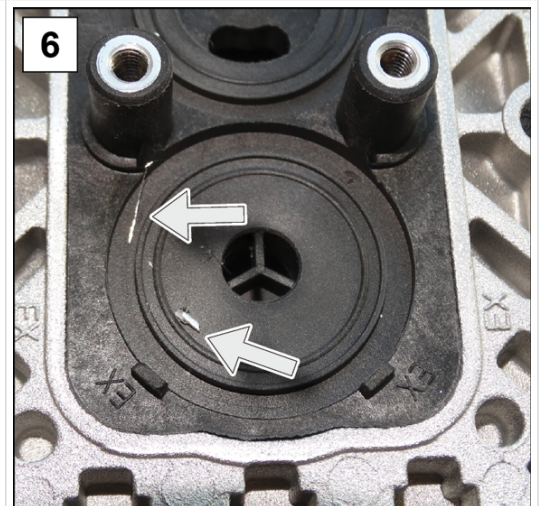

6. Check the surfaces for soiling.



7. Clean soiled surfaces carefully.

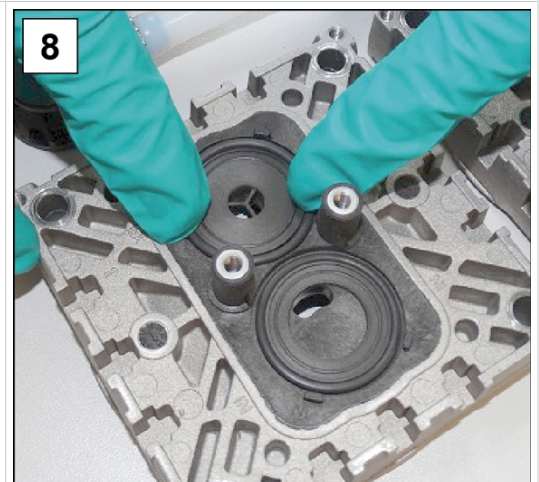

8. Insert new sealing rings into the notches.

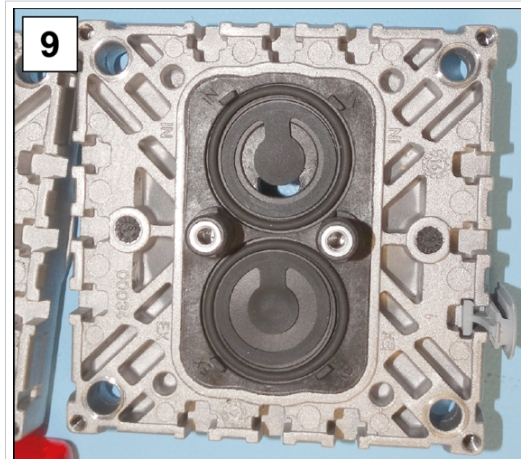

9. Apply the new valves and align them.

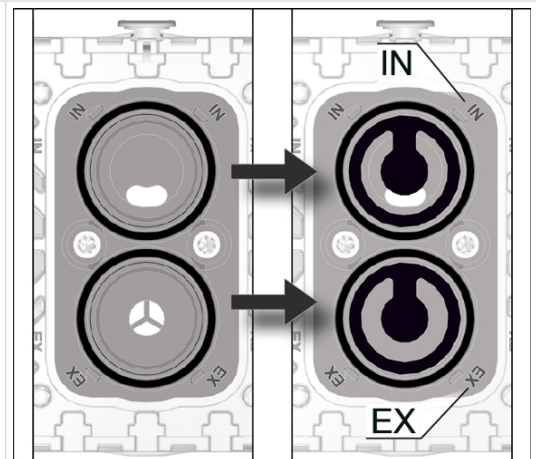

Plan view cutout: Correct positioning of valves.
 IN = Inlet (Inlet)
 EX = Exhaust (Outlet)

→ Example
 Valve replacement

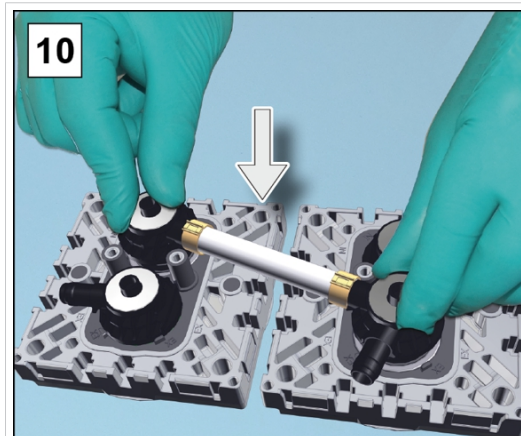

10. Place the individual valve terminals and the two valve terminals with the tubing together with the disk springs on the pump heads.

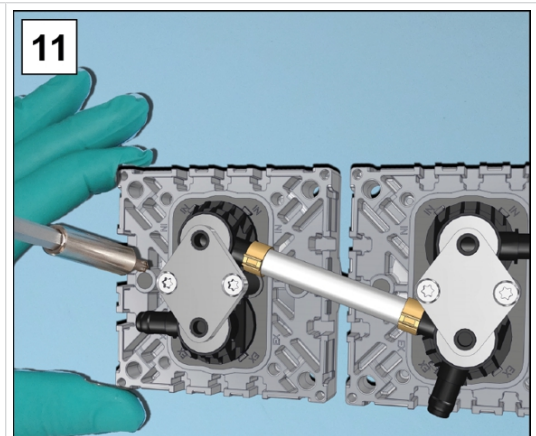

11. Place the clamping brackets onto the valve clusters and tighten the screws by hand at first. Then tighten these with a torque wrench to 3 Nm.

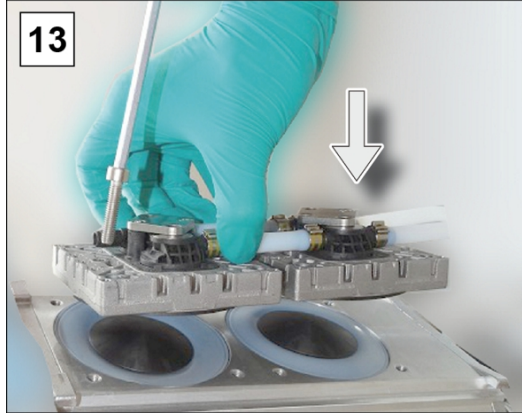
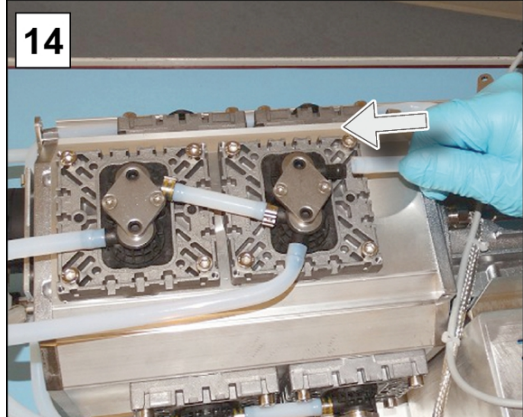
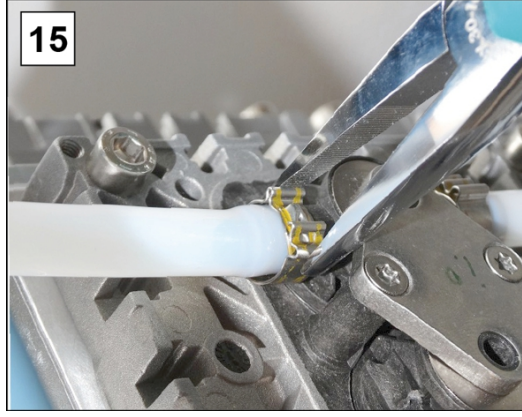
	
<p>12. Carefully press the membranes centrally and flush into the housing opening.</p>	<p>13. Lay the pump head pair on the vacuum pump, and tighten the screw fasteners; hexagon socket wrench size 5.</p>
	
<p>14. Slide the molded hoses back onto the hose nozzles.</p>	<p>15. Close the hose clamps on the hose nozzles (e.g., with flat nose pliers).</p>

Pump head pair, bottom

-> Example
Maintenance of
pump head pair, bot-
tom

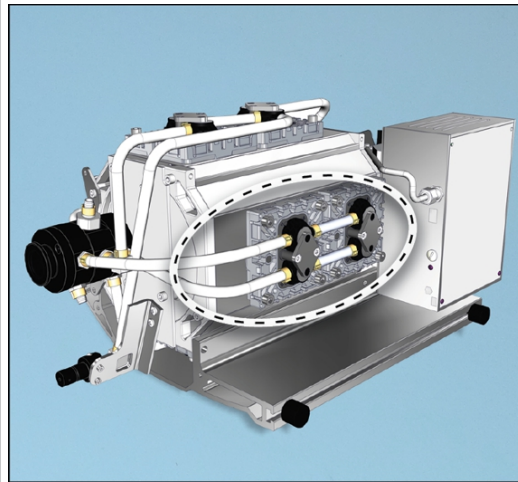

⇒ To change the membranes and valves, proceed exactly as described for the pump head pair, right-side → **Pump head pair, right on page 66.**

Pump head pair, left side and top

-> Example
Maintenance of
pump head pair, left
and top

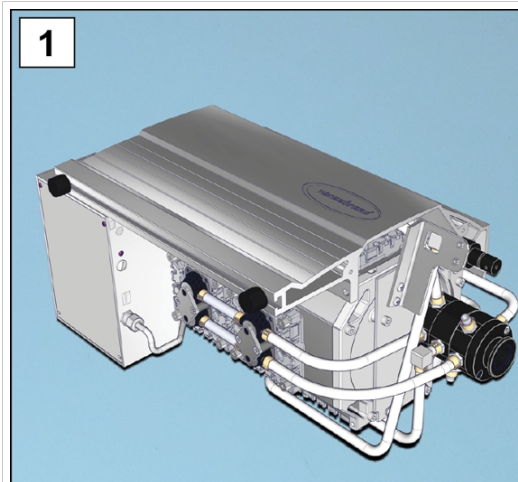

1. Turn the pumping unit so that the side panel is facing upwards.

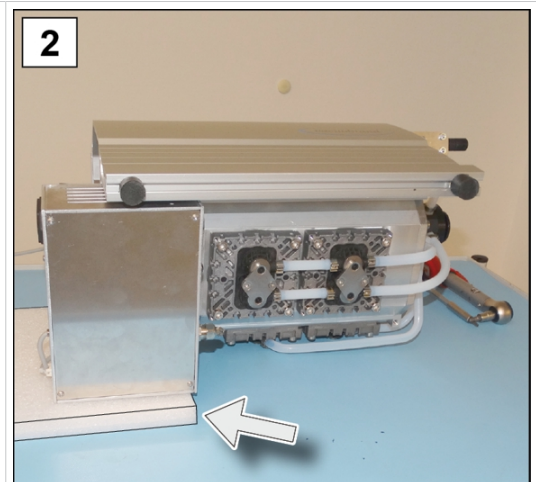

2. Provide support for the pumping unit, e.g. with rigid foam under the housing of the frequency converter.

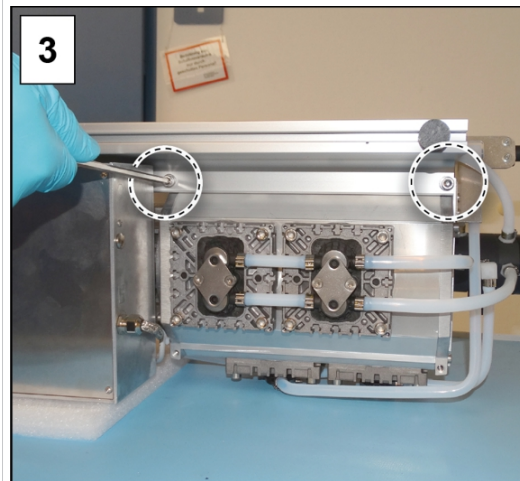

3. Unscrew the screw fasteners of the side panel; hexagon wrench size 5.

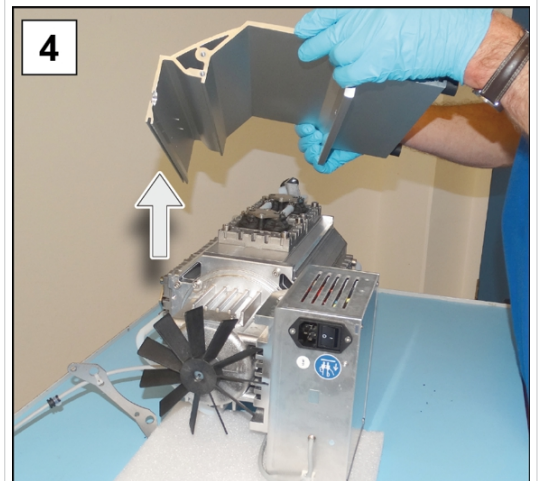

4. Lift the side panel from the pump.

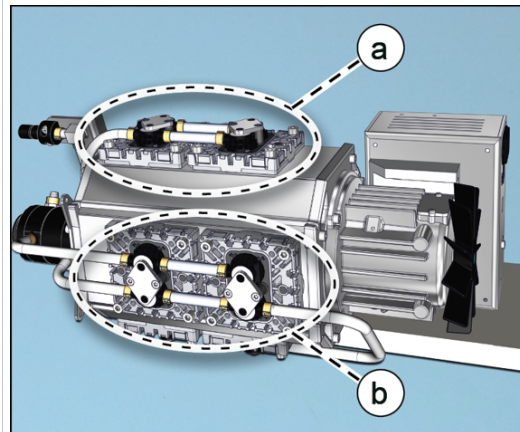

(a) Pump head pair, left
(b) Pump head pair, top

5. To change the membranes and valves, proceed exactly as described for the pump head pair, right-side → **Pump head pair, right on page 66.**

Assembling device and housing parts

Before you put the pumping unit back into operation, all device and housing parts that were removed must first be re-attached.

Assembling the side panels

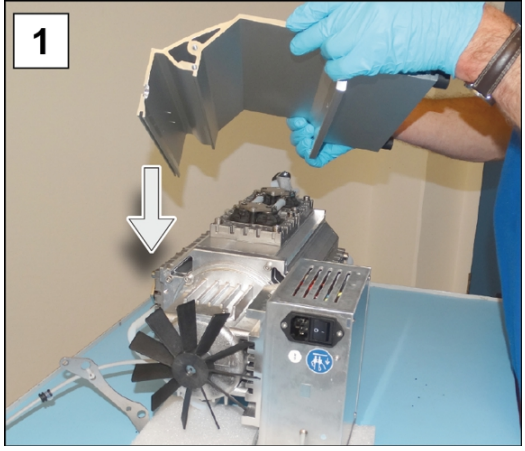
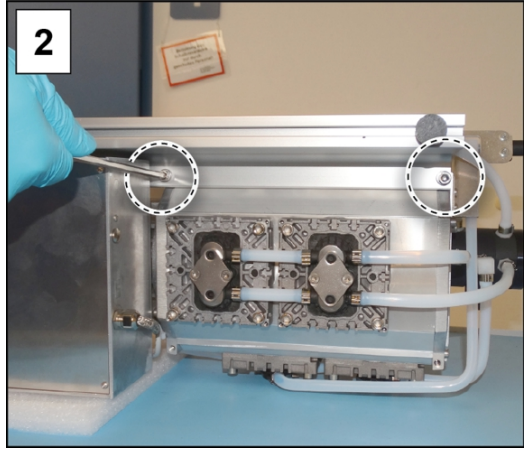
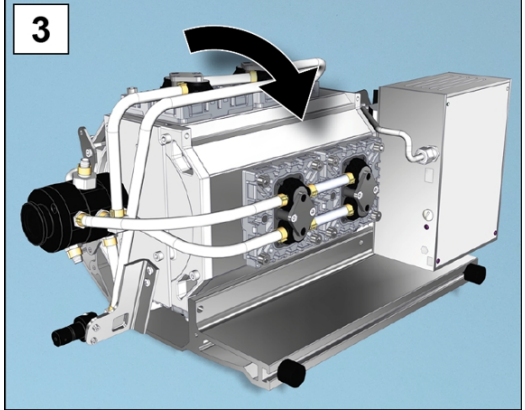
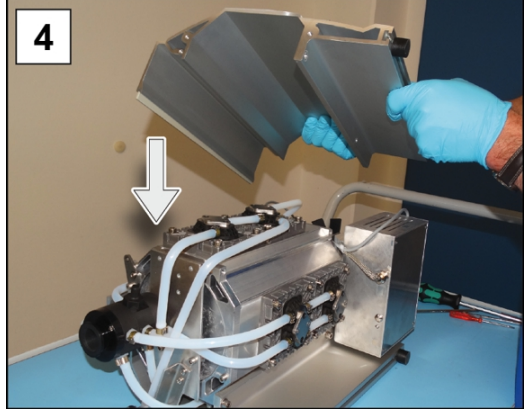
	
<p>1. Attach the side panels onto the pump.</p>	<p>2. Tighten the screw fasteners of the side panel; hexagon wrench size 5.</p>
	
<p>3. Turn the pumping unit up-right and make sure that it is in a secure standing position.</p>	<p>4. Attach the side panels onto the pump.</p>

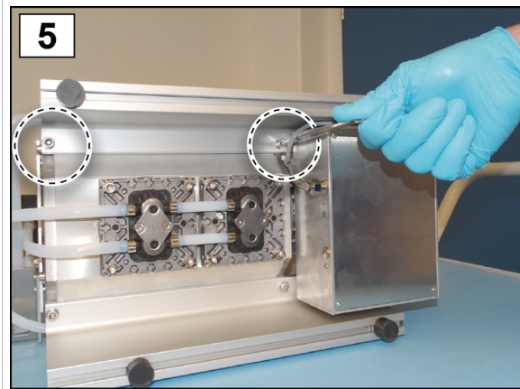

5. Tighten the screw fasteners of the side panel; hexagon wrench size 5.

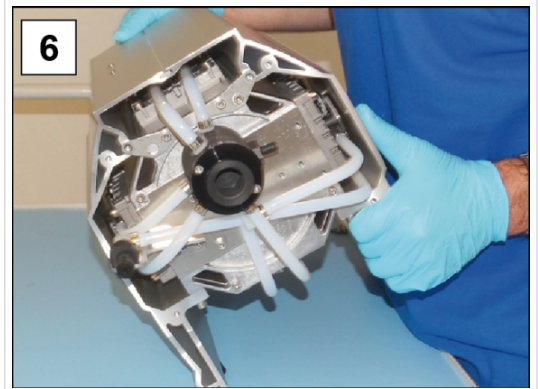

6. Place the pump on rubber feet.

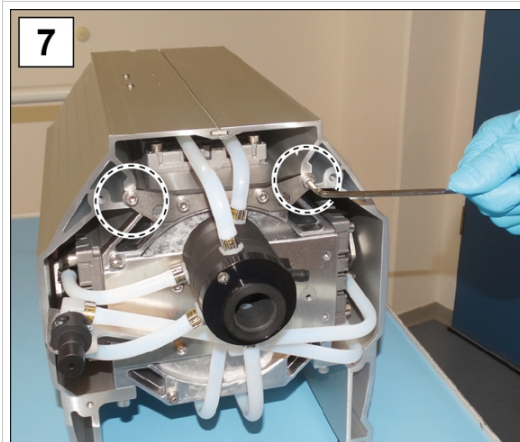

7. Tighten the 2 outer screws from the retaining plate; hexagon socket wrench size 4.



8. Attach the cable in the rear gap.

Assemble the rear housing section

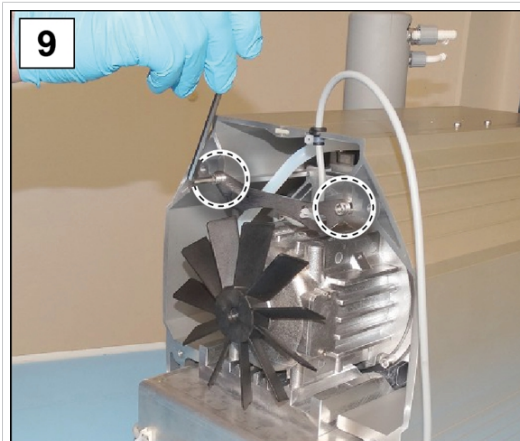

9. Tighten the screws from the side panel retaining plate; hexagon socket wrench size 4.

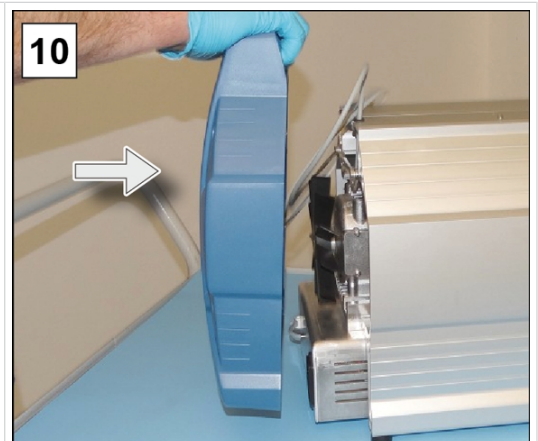

10. Attach the rear housing section.

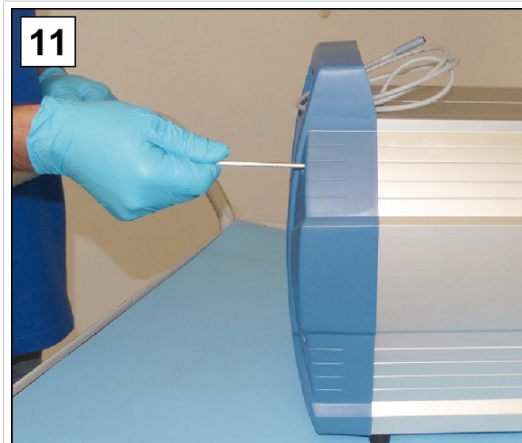

11. Tighten the screws from the housing section; hexagon socket wrench size 4.

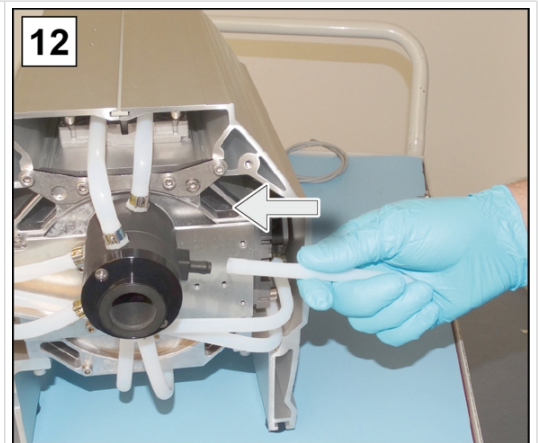

12. Attach the molded hose for the EK.

Assembling the EK

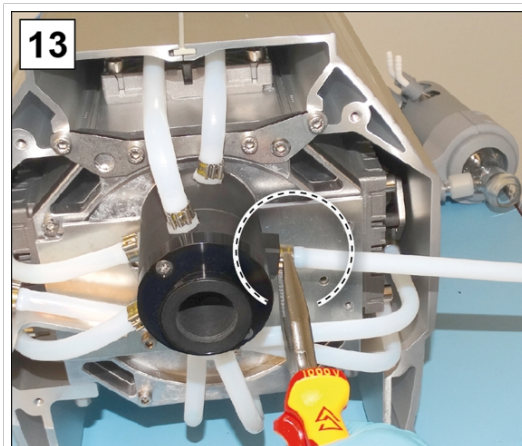

13. Close the hose clamp (e.g., with flat nose pliers).

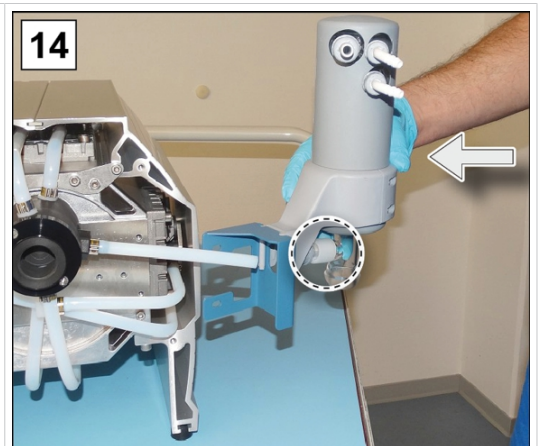

14. Push the EK together with the bracket onto the molded hose.



15. Fasten the union nut from the inflow EK.

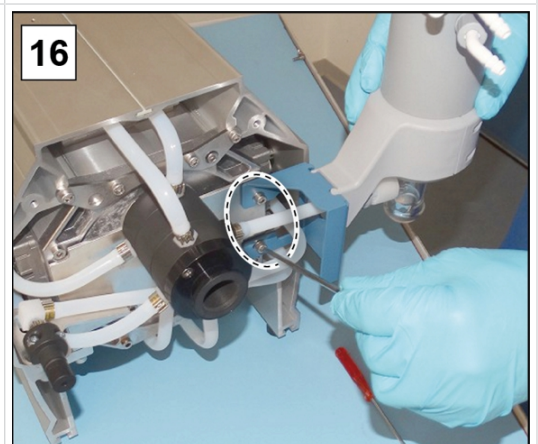

16. Tighten the two screws from the EK bracket; hexagon socket wrench size 4.

Assemble the front housing section

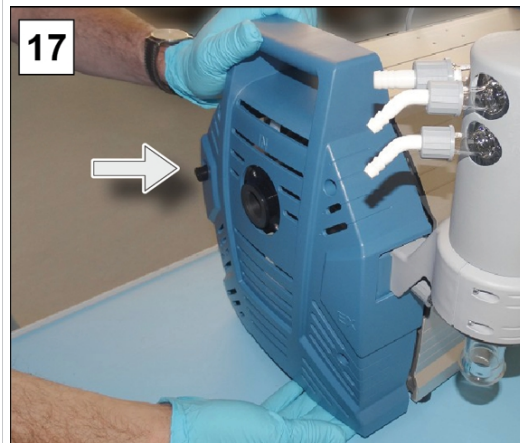

17. Attach the front housing section.



18. Tighten the screws from the housing section; hexagon socket wrench size 4.

Assembling attachment parts



19. Place the cap onto the gas ballast.



20. Fasten the inlet separator to the tension ring.



21. Fasten the glass flask to the inlet IN.

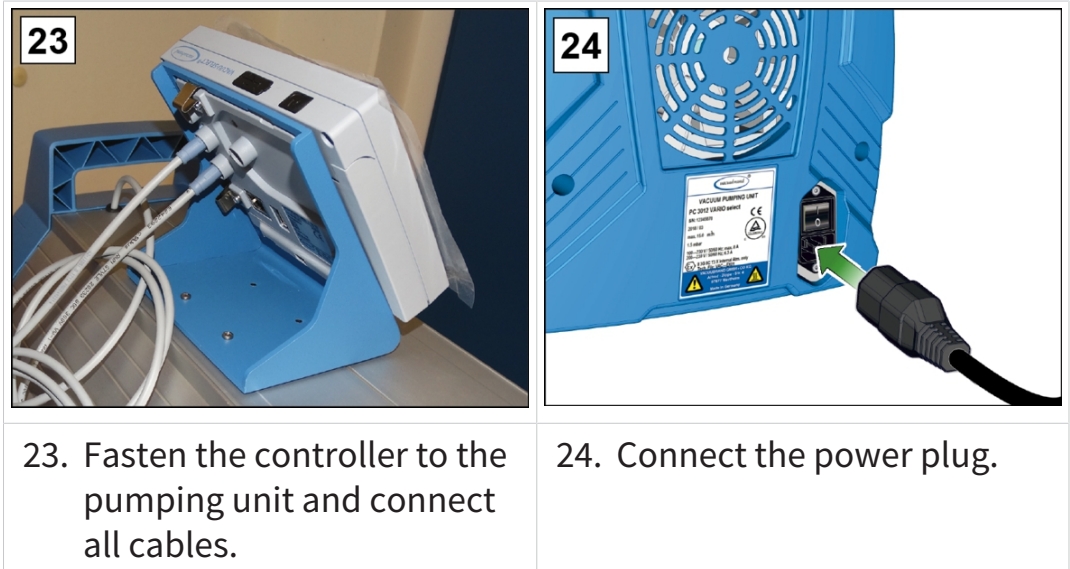

22. Fasten the glass flask to the EK.

**If the maintenance work is fully completed:**





- ⇒ Connect the hosing for operation.
- ⇒ Connect the pumping unit to the power supply.
 - Pumping unit ready for restart.
 - Without reconnection -> Pumping unit prepared for storage.

7.3.4 Device fuse replacement

At the rear of the pumping unit, at the power supply, there are 2 device fuses, type: 8 AT 5x20.

Replace device fuse

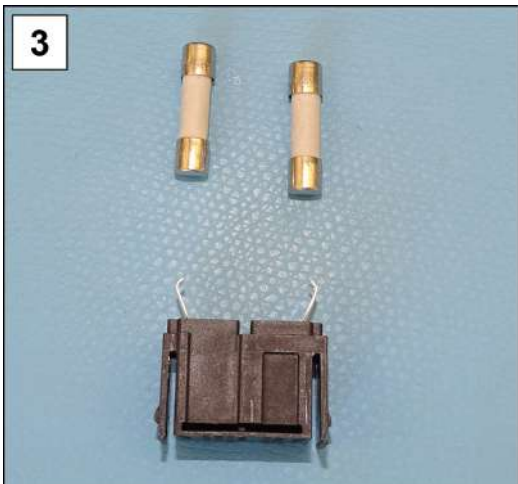
-> Example
Check and replace
the device fuse

	
<p>1. First unplug the power connector and then unlock the fuse drawer.</p>	<p>2. Gently pull the securing drawer out of the appliance connector.</p>
	
<p>3. Replace defective fuses.</p>	<p>4. Insert the securing drawer into the device connector and press it.</p>

8 Annex

8.1 Technical data

Product description
Product names

Chemistry pumping unit series

PC 3010 NT VARIO select	PC 3016 NT VARIO select
PC 3012 NT VARIO select	PC 3012 NT VARIO select EKP

Technical data

Technical data

Ambient conditions		(US)
Ambient temperature	10 – 40°C	50 – 104°F
Installation height, max.	2,000 m above sea level	6562 ft above sea level
Humidity	30–85%, non-condensing	
Degree of contamination	2	
Impact energy	5 J	
Protection class (IEC 60529)	IP 40	
Protection class (UL 50E)	Type 1	
Avoid condensate or contamination from dust, liquids, and corrosive gases.		
Operating conditions		(US)
Operating temperature	10 – 40°C	50 – 104°F
Storage/transport temperature	-10 – 60°C	14 – 140°F
Maximum permissible media temperature (gas) of non-explosive atmospheres:		
Continuous operation Inlet pressure > 100 mbar (75 Torr), high gas load	10 – 40°C	50 – 104°F
Continuous operation Inlet pressure < 100 mbar (75 Torr), low gas load	0 – 60°C	32 – 140°F
Short term (< 5 minutes) Inlet pressure < 100 mbar (75 Torr), low gas load	-10 – 80°C	14 – 176°F
ATEX conformity	II 3/- G Ex h IIC T3 Gc X Internal Atm. Only Tech. File: VAC-EX02	

Maximum permissible media temperature (gas) of  atmospheres:		
Continuous operation Inlet pressure > 100 mbar (75 Torr), high gas load	10 – 40°C	50 – 104°F
Continuous operation Inlet pressure < 100 mbar (75 Torr), low gas load	10 – 40°C	50 – 104°F
Short term (< 5 minutes) Inlet pressure < 100 mbar (75 Torr), low gas load	10 – 40°C	50 – 104°F
Connections		
Vacuum, inlet IN	Small flange SF DN 25/ Hose nozzle SW 15	
Gas ballast GB	Gas ballast valve, manual	
Inert gas adapter – OPTION	Small flange GB NT SF DN 16 Hose nozzle GB NT DN 6-10	
Venting valve (venting with inert gas) – OPTION	Silicon rubber hose 4-5	
Coolant EK	Hose nozzle DN 6-8, 2	
Outlet EX	Hose nozzle DN 8-10	
Cold-device plug	+ power connection CEE, CH, CN, UK, IN, US	
Plug-in connector	VACUU·BUS®	
Electrical data		(US)
Rated voltage	200–230 VAC ± 10%	100–120 VAC ± 10%
Power frequency	50/60 Hz	50/60 Hz
Rated current, max.	3.5 A	8 A
Rated power	530 W	0.71 hp
Speed range, min.– max.	30–2,400 rpm	30–2,400 rpm
Motor protection	Temperature sensor	
Overvoltage category	II	
Interface	VACUU·BUS®	
Power cable	2 m	
Device fuse 2 pc.	8A/T 5×20	
Vacuum data		(US)
Inlet pressure/outlet pressure/ differential pressure, absolute	1.1 bar	16.0 psi
Pressure at gas connections, absolute max.	1.2 bar	17.5 psi

Sensor	VACUU·SELECT Sensor	
Measurement principle	Ceramic diaphragm (aluminum oxide), capacitive, gas-type independent, absolute pressure	
Measurement accuracy	±1 mbar/hPa/Torr, ± 1 digit (after adjustment, constant temperature)	
Upper measurement limit	1,080 mbar	810 Torr
Lower measurement limit	0.1 mbar	0.1 Torr
Temperature drift	< 0.15 mbar/K	< 0.11 Torr/K
PC 3010 NT VARIO select		
Pumping speed, max.	12.8 m ³ /h	7.5 cfm
Ultimate vacuum, absolute	0.6 mbar	0.45 Torr
Ultimate vacuum with GB, absolute	1.2 mbar	0.9 Torr
Number of cylinders/stages	8/4	
PC 3012 NT VARIO select (EKP)		
Pumping speed, max.	14.3 m ³ /h	8.4 cfm
Ultimate vacuum, absolute	1.5 mbar	1.1 Torr
Ultimate vacuum with GB, absolute	3 mbar	2.2 Torr
Number of cylinders/stages	8/3	
PC 3016 NT VARIO select		
Pumping speed, max.	19.3 m ³ /h	11.4 cfm
Ultimate vacuum, absolute	70 mbar	53 Torr
Ultimate vacuum with GB, absolute	100 mbar	75 Torr
Number of cylinders/stages	8/1	
Weights* and dimensions (L × W × H)		(US)
PC 3010 NT VARIO select	616 mm × 387 mm × 450 mm	24.3 in × 15.2 in × 17.7 in
Weight*	29.7 kg	65.5 lb
PC 3016 NT VARIO select	616 mm × 387 mm × 450 mm	24.3 in × 15.2 in × 17.7 in
Weight*	29.7 kg	65.5 lb
PC 3012 NT VARIO select	616 mm × 387 mm × 450 mm	24.3 in × 15.2 in × 17.7 in
Weight*	29.7 kg	65.5 lb

PC 3012 NT VARIO select EKP	616 mm × 435 mm × 450 mm	24.3 in × 17.1 in × 17.7 in
Weight*	33.6 kg	74.1 lb
* without cable		

Other specifications		(US)
Maximum permissible pressure of the coolant at the EK, absolute	6 bar	87 psi
Permissible range of coolant temperature	-15°C to +20°C	5°F to 68°F
Volume of condensate collection tanks	500 ml	
Sensor type	VACUU·SELECT Sensor	
Controller	VACUU·SELECT	
A-weighted emission sound pressure level ¹⁰ (uncertainty _{KpA} : 3 dB(A))	47 dB(A)	

8.2 Materials affected by media

Materials affected by media

Component	Materials affected by media
Pump	
Head cover	Carbon fiber reinforced ETFE
Diaphragm clamping disk	Carbon fiber reinforced ETFE
Diaphragm	PTFE
Valves PC 3010, PC 3012	FFKM
Valves PC 3016	PTFE
O-rings	FPM
Valve head	Carbon fiber reinforced ECTFE
Pumping unit	
Inlet	PP glass fiber reinforced
Outlet, hose nozzle	PP
Distributor head	Carbon fiber reinforced PPS
Hose connection to the outlet	Carbon fiber reinforced PPS
O-ring on separator	FFKM, NBR

¹⁰ Measurement at ultimate vacuum at 62% speed according to DIN EN ISO 2151:2009 and EN ISO 3744:2011 with outlet line at outlet connection

Pressure relief valve at the emission condenser	Silicone rubber, PTFE film
Emission condenser outlet	PET
Emission condenser	Borosilicate glass
Round bottom flask	Borosilicate glass
Hoses	PTFE
Hose fitting	ETFE, ECTFE
Inlet/outlet Peltronic	PP
Cooling surfaces Peltronic	PFA, PA
Separator (AK)	Glass fiber reinforced PP, PE
Sealing ring/centering ring (AK)	FEP
Adapter KF 25 to hose nozzle 15 mm (AK)	PP
Gas ballast tube	PTFE carbon reinforced
VACUU-SELECT Sensor	
Vacuum sensor	Aluminum oxide ceramic, gold-coated
Measurement chamber	PPS
Small flange OPTION	PP
Sealing ring at the sensor	FFKM
Hose nozzle	PP
Seal on venting valve	FFKM

8.3 Rating plate

Specifications from the type plate



- ⇒ In case of error, take note of the type and serial number from the rating plate.
- ⇒ When contacting our service department, provide the type and serial number from the rating plate. This way we can provide you with targeted support and consultation for your product.

Pumping unit type plate, general

-> Example
Type plate details

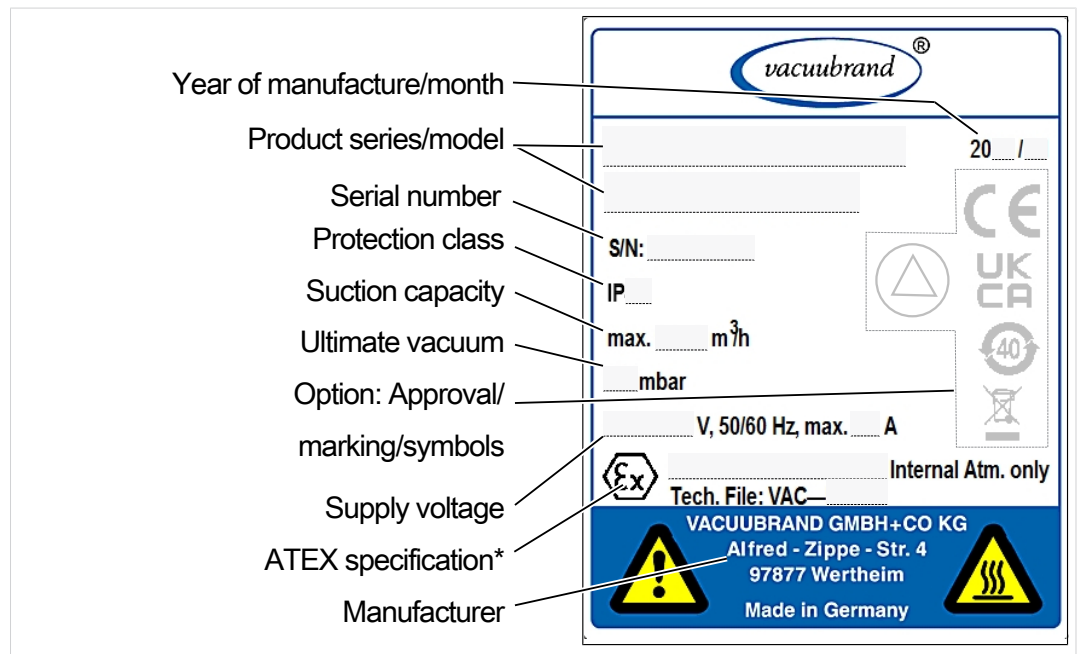

* Specification of the documentation, group and category, marking G (gas), ignition protection type, explosion group, temperature class (see also: Approval ATEX device category).

8.4 Order data

Order data accessories

Accessories	Order No.
Vacuum hose (PVC), DN 6, transparent (sold by the meter)	20686060
Vacuum hose (PVC), DN 8, transparent (sold by the meter)	20686061
Coolant valve VKW-B	20674220
Venting valve VBM-B	20674217
Level sensor	20699908
VACUU·SELECT Sensor	20612881
VSK 3000	20640530
Initial calibration (DAkkS accredited)	20900214
Re-calibration (DAkkS accredited)	20900215

Order data replacement parts

Replacement parts	Order No.	
Hose nozzle 6 curved	20639948	
Hose nozzle DN 6/10	20636635	
Small flange KF DN 16	20635008	
Extension cable VACUU·BUS, 0.5 m	20612875	
Extension cable VACUU·BUS, 2 m	20612552	
Extension cable VACUU·BUS, 10 m	22618493	
Spherical joint clamp VA KS35/25	20637627	
Glass flask/round bottom flask, 500 ml	20638497	
PA knurled nut M14×1 (union nut)	20637657	
PA clamping ring D10 (seal)	20637658	
Emission condenser EK, complete	On request	
Peltronic emission condenser EKP	20636298	
Anti-rotation protection D17×17.5	20635113	
Gas ballast cap	20639223	
Power cable	CEE	20612058
	CH	20676021
	CN	20635997
	IN	20635365
	US	20612065
	UK	20676020

Supply sources

International agents
and dealers

Purchase original accessories and original replacement parts from a branch office of VACUUBRAND GMBH + CO KG or from your local dealer.



- ⇒ You can find information on the complete product range on our website: www.vacuubrand.com.
- ⇒ Your local distributor or VACUUBRAND sales office is available to assist you with orders, questions on vacuum control and optimal accessories.

8.5 Service information

Take advantage of the comprehensive range of services available from **VACUUBRAND GMBH + CO KG**.

Services in detail

Service offer and service range

- Product consultation and practical solutions
- Fast delivery of spare parts and accessories
- Professional maintenance
- Immediate repairs processing
- On-site service (on request)
- Calibration (DAkkS-accredited)
- With Health and Safety Clearance form: return, disposal

Visit our website for further information: www.vacuubrand.com.

Service handling

Follow these headings: VACUUBRAND > Support > [Service](#)



Reduce downtimes, speed up processing. When contacting our service department, please have the required information and documents ready.

- ⇒ Your order can be assigned quickly and easily.
- ⇒ Risks can be excluded.
- ⇒ A short description, photos or diagnostics data help to narrow down the error.

8.6 EU declaration of conformity

EG-Konformitätserklärung für Maschinen EC Declaration of Conformity of the Machinery Déclaration CE de conformité des machines



Hersteller / Manufacturer / Fabricant:

VACUUBRAND GMBH + CO KG · Alfred-Zippe-Str. 4 · 97877 Wertheim · Germany

Hiermit erklärt der Hersteller, dass das Gerät konform ist mit den Bestimmungen der Richtlinien:

Hereby the manufacturer declares that the device is in conformity with the directives:

Par la présente, le fabricant déclare, que le dispositif est conforme aux directives:

- 2006/42/EG
- 2014/30/EU
- 2014/34/EU
- 2011/65/EU, 2015/863

Chemie-Pumpstand / Chemistry pumping unit / Groupe de pompage « chimie »:

Typ / Type / Type: **PC 3010 NT VARIO select / PC 3016 NT VARIO select / PC 3012 NT VARIO select / PC 3012 NT VARIO select EKP**

Artikelnummer / Order number / Numéro d'article: **25744850, 25744851, 25744852, 25744856, 25744857 / 25741850 / 25743850, 25743851, 25743852, 25743856, 25743857 / 25743874**

Seriennummer / Serial number / Numéro de série: Siehe Typenschild / See rating plate / Voir plaque signalétique

Angewandte harmonisierte Normen / Harmonized standards applied / Normes harmonisées utilisées:

EN ISO 12100:2010 (ISO 12100:2010), EN 1012-2:1996 + A1:2009, EN 61010-1:2010 + A1:2019 + A1:2019/AC:2019 (IEC 61010-1:2010 + COR:2011 + A1:2016, modifiziert / modified / modifié + A1:2016/COR1:2019)

EN IEC 61326-1:2021 (IEC 61326-1:2020)

EN 1127-1:2019; EN ISO 80079-36:2016 (ISO 80079-36:2016)

EN IEC 63000:2018 (IEC 63000:2016)

Bevollmächtigter für die Zusammenstellung der technischen Unterlagen / Person authorised to compile the technical file / Personne autorisée à constituer le dossier technique:

Dr. Constantin Schöler · VACUUBRAND GMBH + CO KG · Germany

Ort, Datum / place, date / lieu, date: Wertheim, 07.05.2024

(Dr. Constantin Schöler)

Geschäftsführer / Managing Director / Gérant

ppa.

(Jens Kaibel)

*Technischer Leiter / Technical Director /
Directeur technique*

VACUUBRAND GMBH + CO KG

Alfred-Zippe-Str. 4
97877 Wertheim

Tel.: +49 9342 808-0

Fax: +49 9342 808-5555

E-Mail: info@vacuubrand.com

Web: www.vacuubrand.com

VACUUBRAND®

8.7 UKCA conformity declaration

Declaration of Conformity



Manufacturer:

VACUUBRAND GMBH + CO KG · Alfred-Zippe-Str. 4 · 97877 Wertheim · Germany

Hereby the manufacturer declares that the device is in conformity with the directives:

- Supply of Machinery (Safety) Regulations 2008 (S.I. 2008 No. 1597, as amended by S.I. 2019 No. 696)
- Electromagnetic Compatibility Regulations 2016 (S.I. 2016 No. 1091, as amended by S.I. 2019 No. 696)
- The Equipment and Protective Systems Intended for Use in Potentially Explosive Atmospheres Regulations 2016 (S.I. 2016 No. 1107, as amended by S.I. 2019 No. 696)
- The Restriction of the Use of Certain Hazardous Substances in Electrical and Electronic Equipment Regulations 2012 (S.I. 2012 No. 3032)

Chemistry pumping unit:

Type: **PC 3010 NT VARIO select / PC 3016 NT VARIO select / PC 3012 NT VARIO select / PC 3012 NT VARIO select EKP**

Order number: **25744850, 25744851, 25744852, 25744856, 25744857 / 25741850 / 25743850, 25743851, 25743852, 25743856, 25743857 / 25743874**

Serial number: See rating plate

Designated standards applied:

EN ISO 12100:2010, EN 1012-2:1996+A1:2009, EN 61010-1:2010+A1:2019, EN 61010-1:2010/A1:2019/AC:2019-04
EN 61326-1:2013
EN 1127-1:2019, EN ISO 80079-36:2016
EN IEC 63000:2018

Person authorised to compile the technical file:

Dr. Constantin Schöler · VACUUBRAND GMBH + CO KG · Germany

Place, date: Wertheim, 07.05.2024

(Dr. Constantin Schöler)
Managing Director

ppa.

(Jens Kaibel)

Technical Director

VACUUBRAND GMBH + CO KG

Alfred-Zippe-Str. 4
97877 Wertheim

Tel.: +49 9342 808-0

Fax: +49 9342 808-5555

E-Mail: info@vacuubrand.com

Web: www.vacuubrand.com

VACUUBRAND®

Index

A

Abbreviations used	9
Action instructions (image description)	9
Additional symbols	8
Ambient conditions	29
Assembling the side panels	76
ATEX device category	21
ATEX device category and peripheral devices	21

C

Check the device fuse.....	81
Cleaning, general	57
Connect the outlet	33
Connect the outlet hose.....	33
Connection at the separator flask ...	25
Coolant connection.....	37
Copyright	5

D

Disassembling the EK.....	61
Dismantling device and housing parts	60
Dismantling the housing.....	63
Disposal	22

E

Emission condenser	25
Error-Cause-Remedy.....	53
Example of use: local area vacuum network.....	26
Explanation of safety symbols.....	8
Explanation of usage conditions X ..	22
Explosion-view drawing of pump head pair	65

F

Fine vacuum	11
-------------------	----

I

Improper use	12
Installing the vacuum pump.....	29
Instruction modules.....	6

L

Labels and signs	20
------------------------	----

Looking out for dangers during ventilation	19
--	----

M

Maintenance interval	55
Maintenance of pump heads	59
Materials affected by media	85
Measurement chamber.....	86
Membrane replacement	67
Misuse	13
Modular instructions for use.....	6
Mounting the holding base on the pumping unit	30

O

Observe stability.....	18
Operating elements vacuum controller.....	45
Operator interface.....	44
Operator measures	16
Operator responsibilities	14
Overheating protection	21
Overview of chemistry pumping units	24

P

PC 3012 NT VARIO select	24
PC 3012 NT VARIO select EKP.....	24
PC 3016 NT VARIO select	24
PC 3010 NT VARIO select	24
Peltronic emission condenser	25
Personnel responsibilities	14
Possible residual energies	19
Prepare for maintenance	60
Presentation conventions.....	7
Presentation of action instructions...	9
Pressure display	44
Preventing backlog in the exhaust line	19
Preventing overheating	20
Preventing sources of ignition.....	21
Process display.....	44
Product description	82
Product-specific abbreviations	25
Product-specific terms.....	11
Proper use.....	12

Q	
Qualification description	15
R	
Recommended auxiliary equipment for cleaning and maintenance	55
Replace device fuse	81
Restart procedure	21
Rough vacuum.....	11
S	
Safety instructions	12
Separator flask	25
Surface temperatures	20
Switching on	43
Switching on the pumping unit	43
T	
Target groups	15
Technical data	82
U	
Uncovering the pump head pair.....	64
V	
Vacuum connection at inlet.....	32
Valve replacement	70, 71, 72
Vent with ambient air.....	38
W	
Warning messages	7
Who-does-what matrix	15



Manufacturer:

VACUUBRAND GMBH + CO KG

Alfred-Zippe-Str. 4

97877 Wertheim

GERMANY

Main office:

+49 9342 808-0

Sales:

+49 9342 808-5550

Service:

+49 9342 808-5660

Fax:

+49 9342 808-5555

Email:

info@vacuubrand.com

Web:

www.vacuubrand.com