

化学真空系统 PC 510 select

网站链接



产品说明

对于需要进行电子控制蒸发或干燥过程的应用，我们的PC 500系列化学真空系统是一个很好的选择。备受欢迎的MZ 2C NT二级化学隔膜泵是这系列真空系统的核心组件，常用于含有常规溶剂的中等尺寸的真空应用。集成式的VACUU-SELECT真空控制器搭配了简单易用、基于应用程序的用户界面，内嵌了所有常见的实验室真空应用。VACUU-SELECT真空控制器可满足您所有要求。对于简易实验过程可手动修改控制参数，也可进行全自动蒸馏，或者通过简单的“拖放”操作编辑创建自己的应用程序。在溶剂蒸发过程中，控制器会在探测到溶剂沸腾时压力后切换至两点法控制，保证溶剂沸点被探测到时体系压力能够维持稳定的状态。进气口分离瓶由玻璃制成，外覆一层保护膜，能防止颗粒和液滴进入泵内，防止泵损坏，延长泵的使用寿命。当连接冷水管或循环制冷机时，出气口废气冷凝器可以实现溶剂将近100%回收，从而实现循环经济和环境保护。

性能特点

- 配置图形用户界面的VACUU-SELECT真空控制器能简化实验室工作
- 预定义的应用程序能节省时间，并得到可重复的结果
- 简易操作的应用编辑器允许编辑一系列自定义真空应用
- 性能强劲的真空泵具有优异的化学和冷凝液耐受性
- 高效的溶剂回收率，对环境友好

订购信息

产品名称	额定电源电压 工作频率	电源插头类型	订货号
PC 510 select	230 V 50-60 Hz	CEE	20733150
PC 510 select	230 V 50-60 Hz	CH	20733151
PC 510 select	230 V 50-60 Hz	UK	20733152
PC 510 select	100-115 V 50-60 Hz 120 V 60 Hz	US	20733153
PC 510 select	230 V 50-60 Hz	CN	20733156
PC 510 select	230 V 50-60 Hz	IN	20733157

货品配置

真空系统安装完毕，连接即可使用，附带说明书

配件

- VACUU-SELECT用户管理 VACUU-SELECT User Management (20700900)
- DN 8-10mm (20636588)
- VACUU-LAN®模块 Einstellwinkel 90° (20637873)
- 橡胶真空管 DN 8 mm (20686001)
- 用于收集瓶的液面探测传感器 500 ml (20699908)
- 冷凝水阀 VKW-B (20674220)

技术指标

50 Hz 最大抽速 (mbar)	2 m ³ /h
60 Hz 最大抽速 (cfm)	1.4 cfm
极限真空	7 mbar / 5 torr
极限真空, 使用气镇	12 mbar / 9 torr
泵头数	2
泵级数	2
真空控制器	VACUU·SELECT
的允许环境温度范围 (运行)	10 - 40 °C
的允许环境温度范围 (存放)	-10 - 60 °C
最大出气口压力 (绝对压力)	1.1 bar
进气口连接	软管喷嘴接头 DN 8-10 mm
出气口连接	软管喷嘴接头 DN 8-10 mm
冷却液接口	2个 DN 6-8 mm 软管喷嘴接头
额定电机功率	0.18 kW
额定转速 50/60 Hz	1500/1800 min ⁻¹
防护等级	IP 20
尺寸 (长x宽x高)	418 mm x 272 mm x 457 mm
重量	17.9 kg
噪音水平 50 Hz/1500 Upm/62% (VARIO)/1500 Upm (VARIO-SP)/12500 Upm (VACUU·PURE®)	45 dBA
NRTL 标准	否
通讯	Ethernet (RJ45): Modbus TCP / USB (Type A): Data transfer, software update, RS-232 (additional adapter required)

50 Hz下的抽速曲线

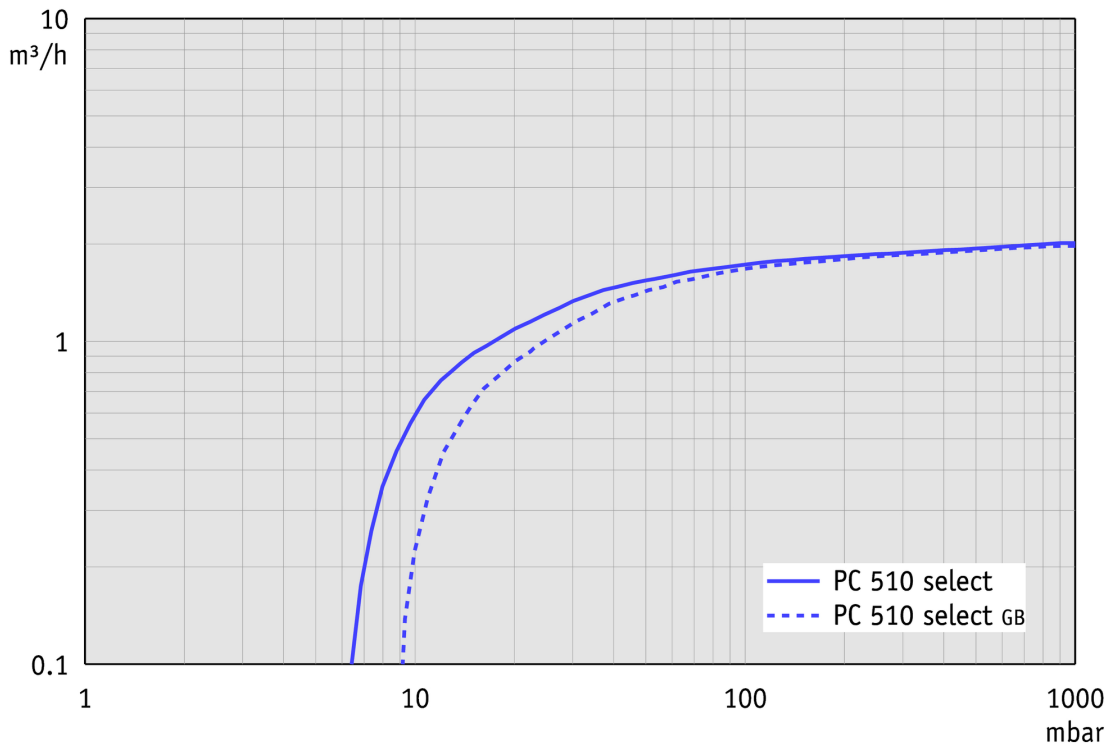

50 Hz下的抽气曲线 (10升容积)

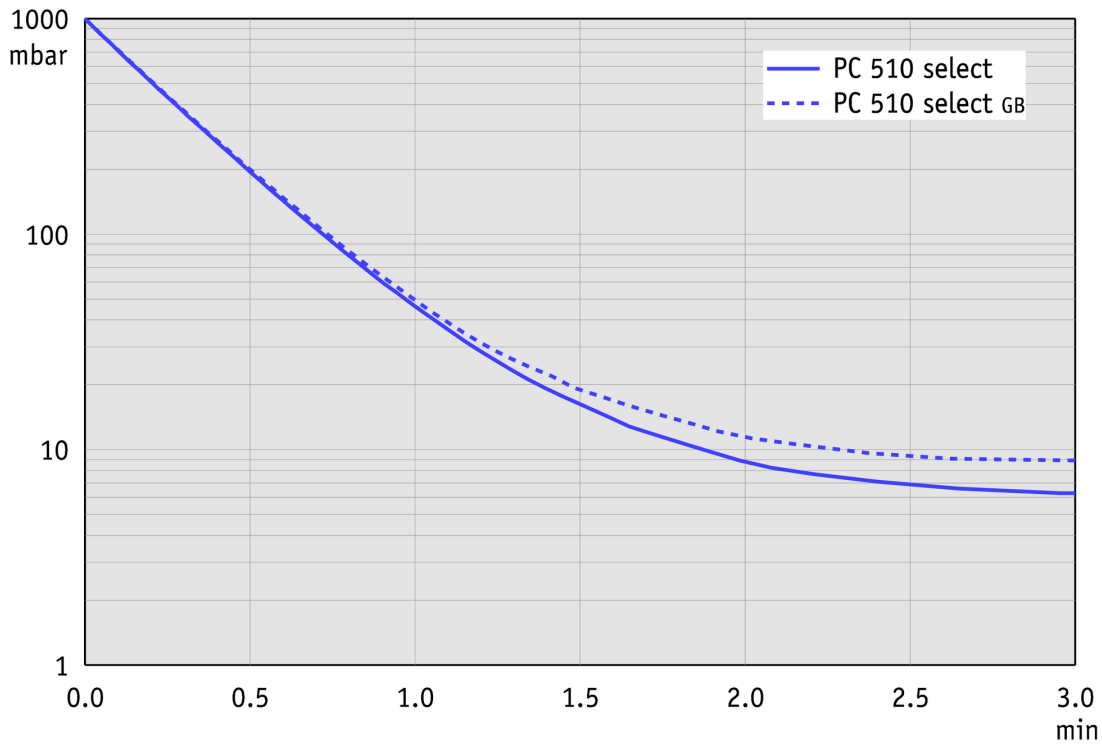

60 Hz下的抽速曲线

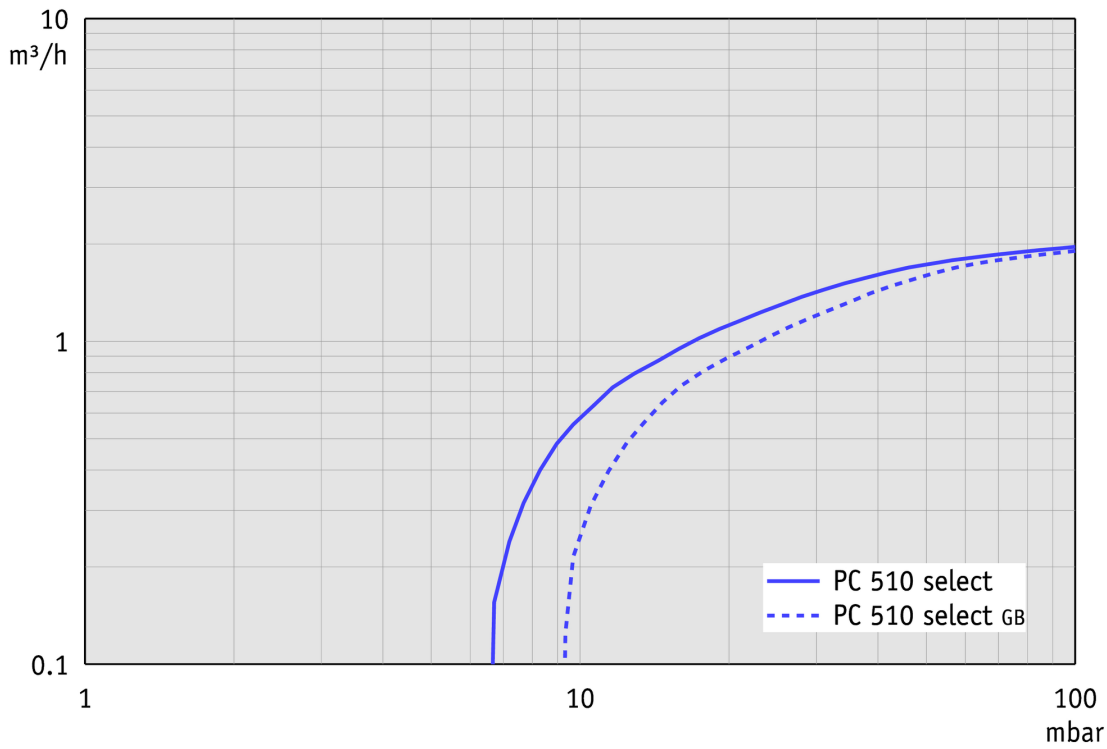

60 Hz下的抽气曲线 (10升容积)

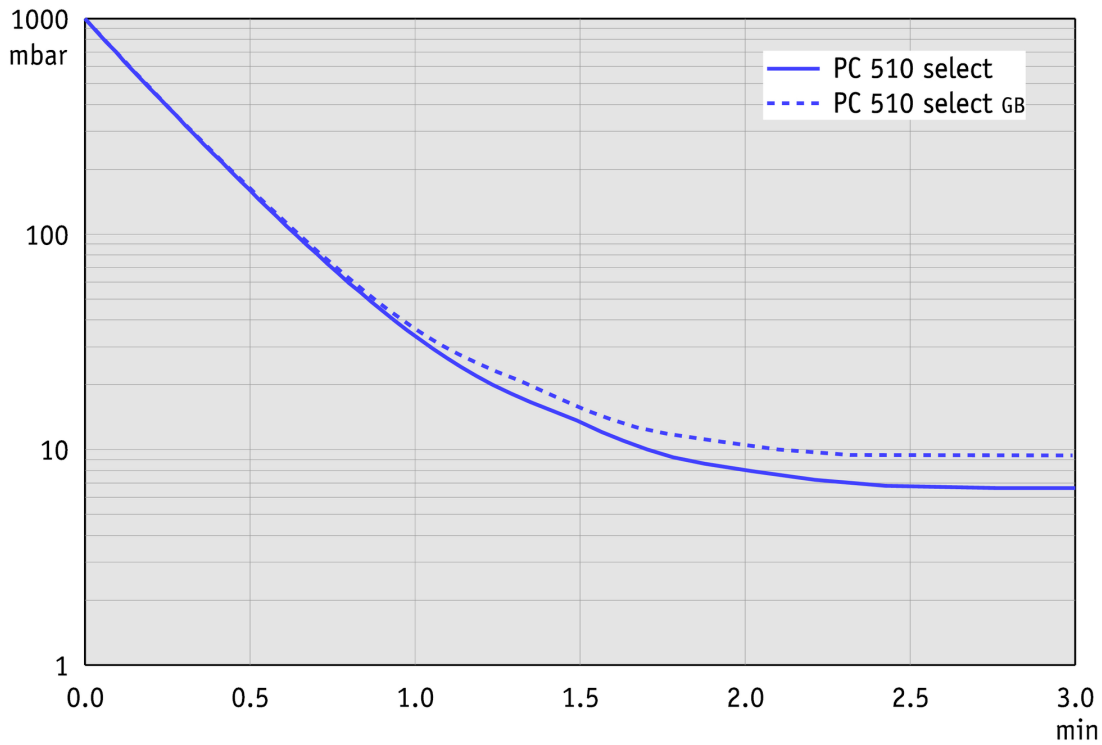

尺寸规格表

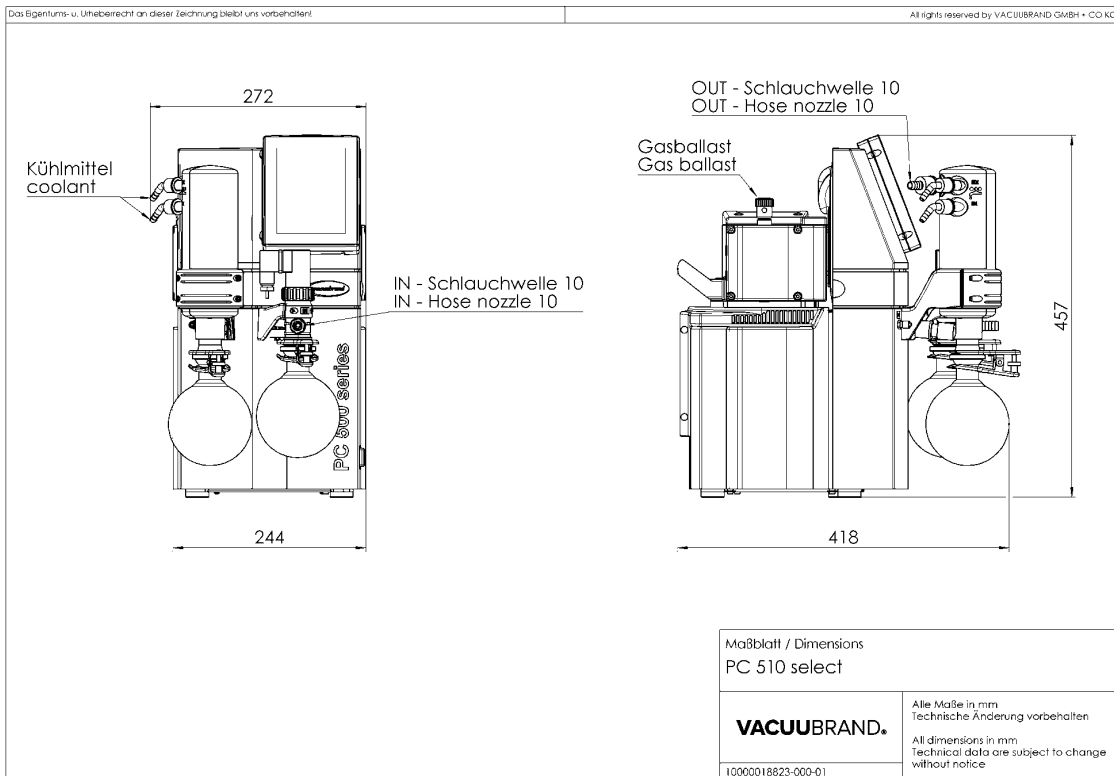

VACUUBRAND GMBH + CO KG
P.O. Box 1664
97877 Wertheim
T +49 9342 808 5550
F +49 9342 808 5555

info@vacuubrand.com
www.vacuubrand.com

VACUUBRAND®

VACUUBRAND is part of the Brand group, a manufacturer of high-quality and innovative laboratory equipment and vacuum technology with a global team of approx. 1,000 employees.

With highly motivated and qualified employees, we manufacture the world's most comprehensive product family for vacuum generation, measurement and control for the rough and fine vacuum range in the laboratory.

All with one goal:

Enabling our customers to run reliable, safe and efficient processes. This is why we commit ourselves to continuous innovation, first-class performance, and outstanding quality.

Engineering excellence is central to our ability to deliver products and solutions renowned for their quality, durability, and reliability. Innovative technology, high quality materials and extensive testing deliver unmatched performance - engineered and manufactured in Germany.

Together with you, our experts will find the best solution for your application and provide you with first-class service along the way.

BRAND (Shanghai) Trading Co., Ltd.
Shanghai, China

T +86 21 6422 2318
info@brand.com.cn
china.brand.com.cn

BRAND Scientific Equipment Pvt. Ltd.
Mumbai, India

T +91 22 42957790
customersupport@brand.co.in
www.brand.co.in

BRANDTECH® Scientific, Inc.
Essex, CT. United States of America

T +1 860 767 2562
info@brandtech.com
www.brandtech.com