

# 真空吸液系统 BVC basic G



网站链接

## 产品说明

BioChem-VacuuCenter BVC basic真空吸液系统设计用于有外置真空源时使用，如有隔膜泵或真空网路（如VACUU-LAN®），不需要供电。耐化学腐蚀的机械真空控制器总会确保最佳的真空条件。控制器仅当需要时开启，因此可以限制真空端口的气载量。可将收集液体的蒸发量降到最低。集成在瓶盖上的进气口管路减少气溶胶和泡沫的行程，确保疏水性灭菌过滤器较长的维护寿命。该吸液系统可提供配4升PP瓶子的BVC basic型号或配2升带覆膜的硼硅酸盐瓶子的BVC basic G型号。

## 性能特点

- 机械真空调节器 带集成止回阀，用以提供最佳的工作真空状态，减少真空网路内的气载量
- 基座稳定，无需供电操作，使用便捷
- 经设计的高温高压灭菌的收集瓶，减少气溶胶或泡沫的生成；高温高压灭菌的快速连接件为可选附件
- VacuuHandControl (VHC<sup>PTO</sup>)吸液手柄配有穿过式吸管 - 不会被所吸介质污染手柄
- 疏水性0.2微米灭菌过滤器 - 大大降低了真空系统被污染的风险；包括收集瓶在内可整套系统高温高压灭菌

## 订购信息

产品名称	额定电源电压 工作频率	电源插头类型	订货号
BVC basic G			20727100

## 货品配置

针对已有真空源的整套吸液系统，带自动真空控制，内径为6/10mm的喷嘴软管接口（用于连接真空源），VacuuHandControl VHC吸液手柄，2升玻璃收集瓶，说明书

## 配件

- VacuuHandControl VHC<sup>PRO</sup> (20688061)
- BVC 2升玻璃瓶 BVC (20635809)
- BVC (20635871)
- VHC<sup>PRO</sup>吸液手柄支架 VHC<sup>PRO</sup> (20635680)
- VHC<sup>PRO</sup> 八道吸头适配器，带吸头脱卸按钮 BVC (20635679)

## 技术指标

真空控制器	机械真空控制器
收集瓶	2l Glass
的允许环境温度范围（运行）	10 - 40 °C
的允许环境温度范围（存放）	-10 - 60 °C
最大出气口压力（绝对压力）	1.1 bar
进气口连接	手柄
出气口连接	软管喷嘴接头 DN 6-10 mm
防护等级	IP 54
尺寸（长x宽x高）	230 mm x 180 mm x 430 mm
重量	3.2 kg
NRTL 标准	否

尺寸规格表

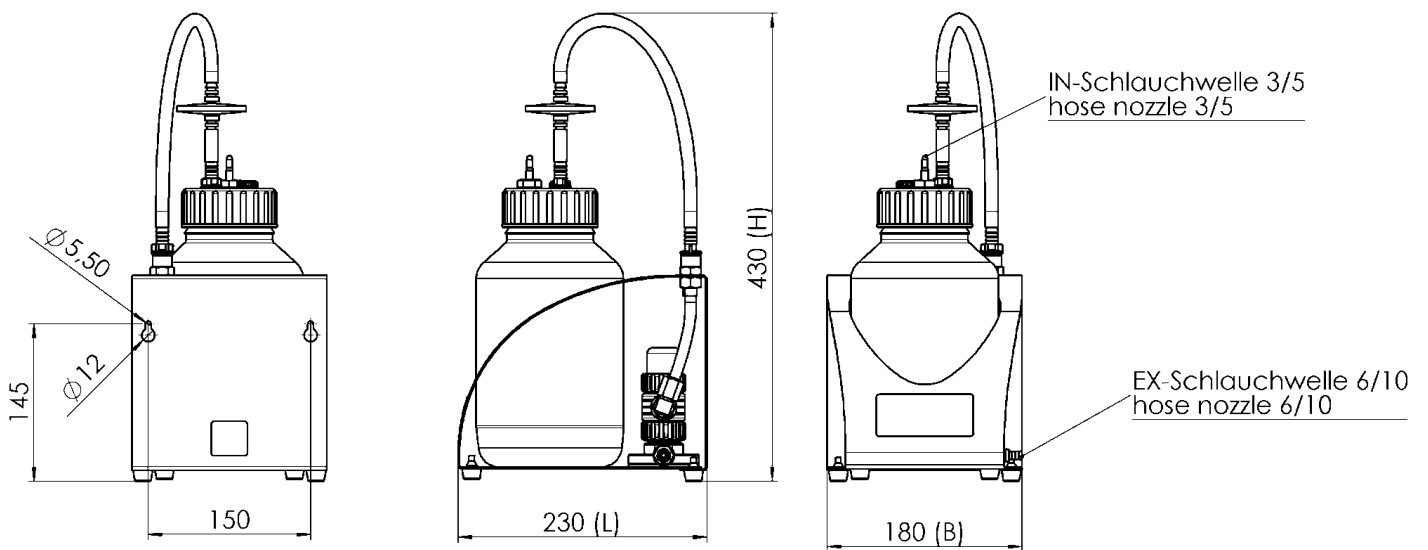

Alle Maße / all dimensions (mm)

VACUUBRAND BVC basic G  
Version 2012/10/09

VACUUBRAND GMBH + CO KG  
P.O. Box 1664  
97877 Wertheim  
T +49 9342 808 5550  
F +49 9342 808 5555

info@vacuubrand.com  
www.vacuubrand.com

**VACUUBRAND®**

VACUUBRAND is part of the Brand group, a manufacturer of high-quality and innovative laboratory equipment and vacuum technology with a global team of approx. 1,000 employees.

With highly motivated and qualified employees, we manufacture the world's most comprehensive product family for vacuum generation, measurement and control for the rough and fine vacuum range in the laboratory.

**All with one goal:**

Enabling our customers to run reliable, safe and efficient processes. This is why we commit ourselves to continuous innovation, first-class performance, and outstanding quality.

Engineering excellence is central to our ability to deliver products and solutions renowned for their quality, durability, and reliability. Innovative technology, high quality materials and extensive testing deliver unmatched performance - engineered and manufactured in Germany.

Together with you, our experts will find the best solution for your application and provide you with first-class service along the way.

BRAND (Shanghai) Trading Co., Ltd.  
Shanghai, China

T +86 21 6422 2318  
info@brand.com.cn  
china.brand.com.cn

BRAND Scientific Equipment Pvt. Ltd.  
Mumbai, India

T +91 22 42957790  
customersupport@brand.co.in  
www.brand.co.in

BRANDTECH® Scientific, Inc.  
Essex, CT. United States of America

T +1 860 767 2562  
info@brandtech.com  
www.brandtech.com