

隔膜泵 ME 4R NT

网站链接



产品说明

该款单级隔膜泵可同时作为一款真空获得装置和压缩机。所有与所抽介质接触的部件均采用铝或精挑细选的塑料（PTFE材质的膜片和阀）。该泵可广泛用于非腐蚀性气体。ME 4R NT的进气口和出气口都连有一个调节阀，可分别用于真空和过压调节，压缩压力和真空度都可进行调节。进气口真空度和出气口压力值都可由压力计显示。

性能特点

- 无油抽气、排空和压缩
- 抽速大，即使接近极限真空时仍具有很高的抽气速度
- 采用调节阀可调整出气口压力和真空度
- 振动极低
- 超长的膜片寿命，无需维护的驱动系统，整体维护成本低

订购信息

产品名称	额定电源电压 工作频率	电源插头类型	订货号
ME 4R NT	230 V 50-60 Hz	CEE	20731100
ME 4R NT	230 V 50-60 Hz	UK, IN	20731102
ME 4R NT	100-115 V 50-60 Hz 120 V 60 Hz	US	20731103

货品配置

泵体安装完毕，连接即可使用，附带说明书

配件

- 橡胶真空管 DN 8 mm (20686001)

技术指标

50 Hz 最大抽速 (mbar)	3.8 m ³ /h
60 Hz 最大抽速 (cfm)	2.5 cfm
极限真空	100 mbar / 75 torr
泵头数	2
泵级数	1
真空控制器	Manometer
的允许环境温度范围 (运行)	10 - 40 °C
的允许环境温度范围 (存放)	-10 - 60 °C
最大出气口压力 (绝对压力)	4 bar
进气口连接	软管喷嘴接头 DN 8-10 mm
出气口连接	软管喷嘴接头 DN 8-10 mm
额定电机功率	0.18 kW
额定转速 50/60 Hz	1500/1800 min ⁻¹
防护等级	IP 40
尺寸 (长x宽x高)	254 mm x 268 mm x 290 mm
重量	11.5 kg
噪音水平 50 Hz/1500 Upm/62% (VARIO)/1500 Upm (VARIO-SP)/12500 Upm (VACUU·PURE®)	45 dBA
NRTL 标准	是

50 Hz下的抽速曲线

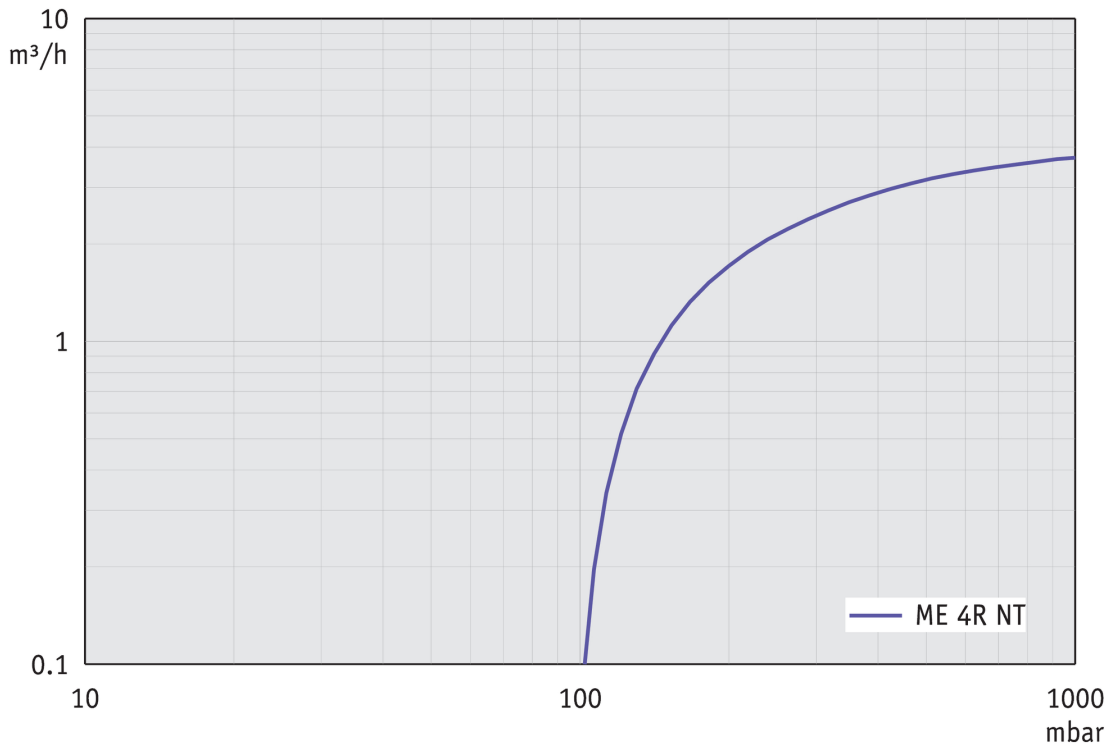

50 Hz下的抽气曲线 (10升容积)

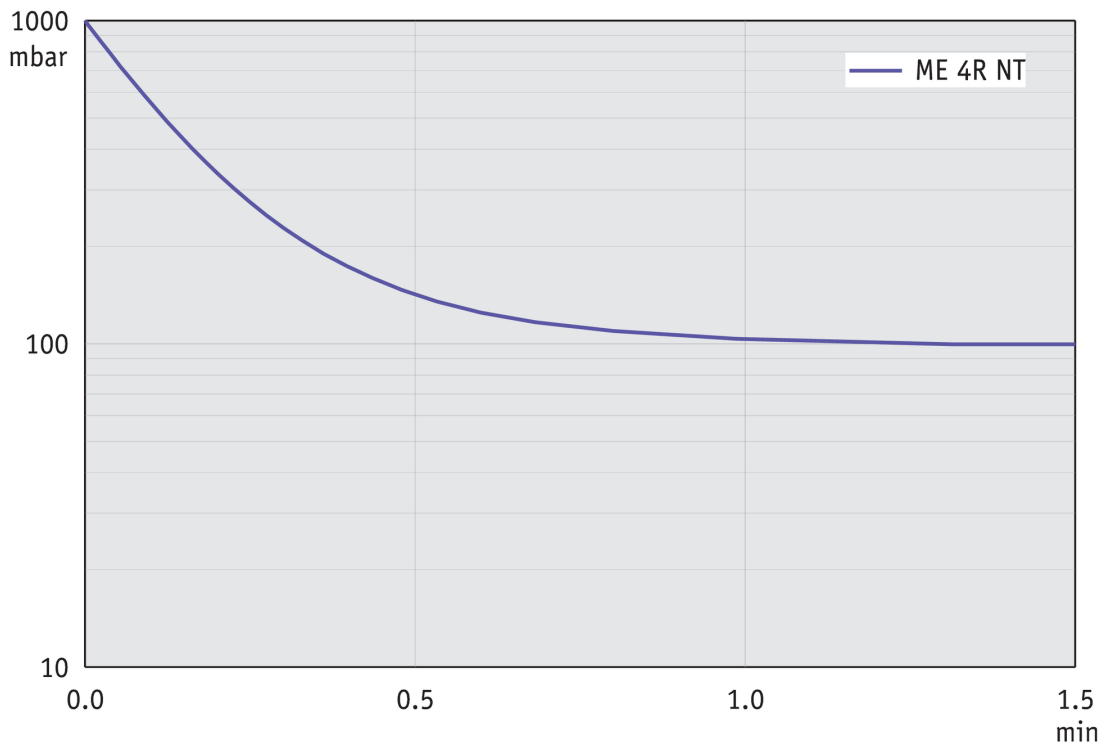

60 Hz下的抽速曲线

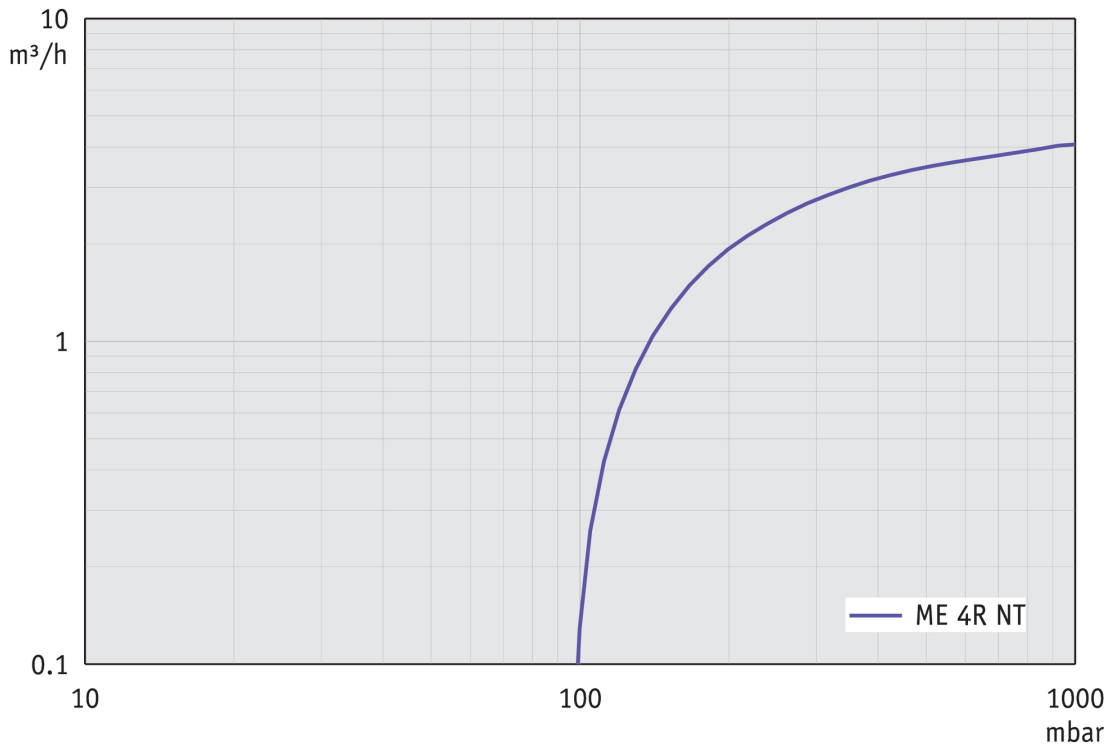

60 Hz下的抽气曲线 (10升容积)

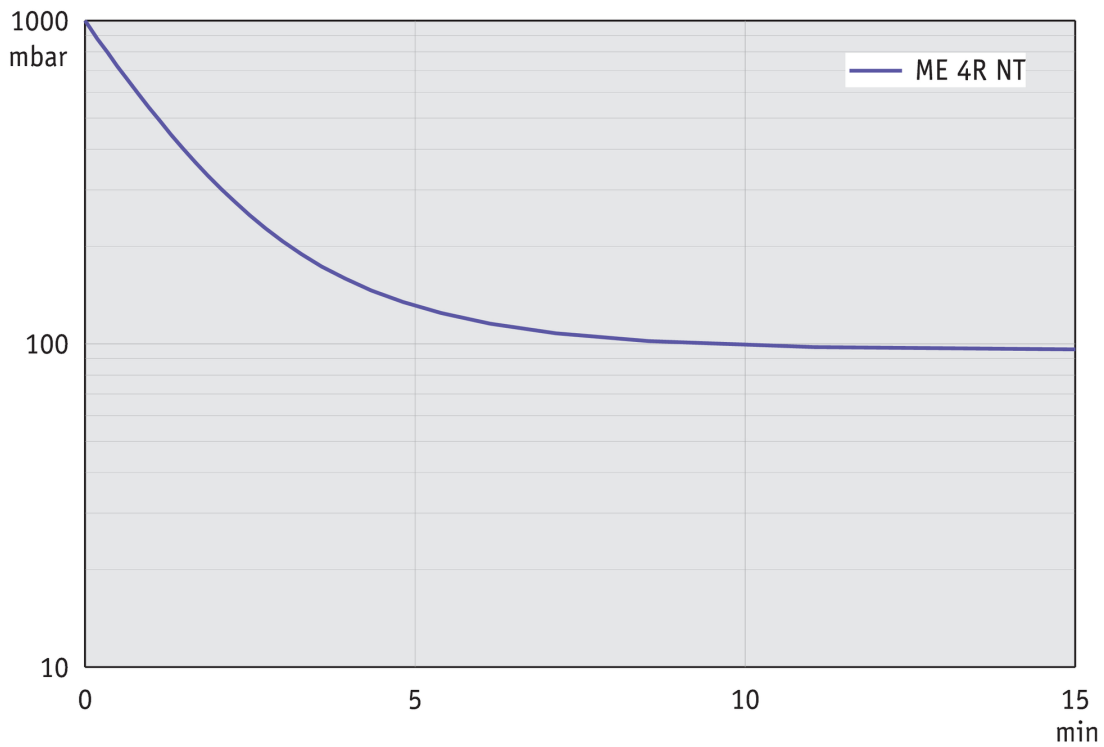

尺寸规格表

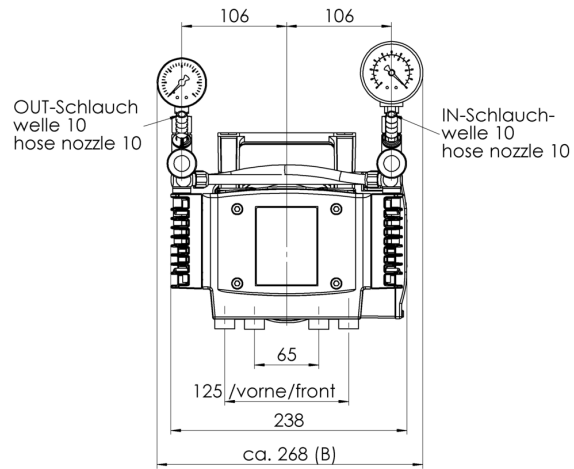
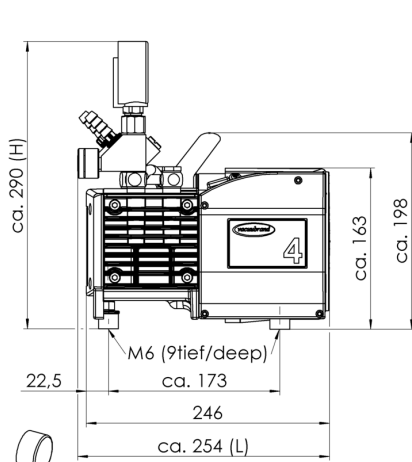

Alle Maße / all dimensions (mm)

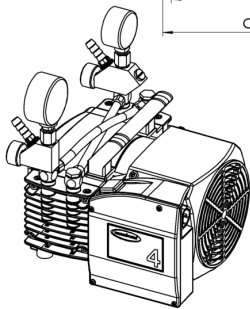

ME 4R NT
Version 03

VACUUBRAND GMBH + CO KG
P.O. Box 1664
97877 Wertheim
T +49 9342 808 5550
F +49 9342 808 5555

info@vacuubrand.com
www.vacuubrand.com

VACUUBRAND®

VACUUBRAND is part of the Brand group, a manufacturer of high-quality and innovative laboratory equipment and vacuum technology with a global team of approx. 1,000 employees.

With highly motivated and qualified employees, we manufacture the world's most comprehensive product family for vacuum generation, measurement and control for the rough and fine vacuum range in the laboratory.

All with one goal:

Enabling our customers to run reliable, safe and efficient processes. This is why we commit ourselves to continuous innovation, first-class performance, and outstanding quality.

Engineering excellence is central to our ability to deliver products and solutions renowned for their quality, durability, and reliability. Innovative technology, high quality materials and extensive testing deliver unmatched performance - engineered and manufactured in Germany.

Together with you, our experts will find the best solution for your application and provide you with first-class service along the way.

BRAND (Shanghai) Trading Co., Ltd.
Shanghai, China

T +86 21 6422 2318
info@brand.com.cn
china.brand.com.cn

BRAND Scientific Equipment Pvt. Ltd.
Mumbai, India

T +91 22 42957790
customersupport@brand.co.in
www.brand.co.in

BRANDTECH® Scientific, Inc.
Essex, CT. United States of America

T +1 860 767 2562
info@brandtech.com
www.brandtech.com