

Diaphragm pump MZ 2D NT

[Link to the website](#)



Product description

Diaphragm pumps are an excellent solution for continuous, oil-free evacuation and pumping of gases. All parts in these MZ 2 series pumps that are in contact with pumped media are made of aluminum, stainless steel and selected plastics, allowing a wide range of applications for non-corrosive gases. The two-stage construction provides the advantageous combination of high pumping speed and an ultimate vacuum down to 4 mbar. The highly flexible fabric-reinforced double diaphragms made of FKM provide high reliability and extended operating life. The NT-series features further improved performance data and compact design.

Performance features

- contamination-free pumping and evacuation
- high flow rate even near ultimate vacuum
- whisper quiet and very low vibration
- exceptionally long diaphragm life and maintenance-free drive system for low lifetime costs
- This pump is supplied without a power cable. You can order the power cable in our online store separately with item number 20612065.

Ordering data

Product name	Nominal mains voltage mains frequency	Plug type	Articleno.
MZ 2D NT	200-230 V 50-60 Hz 100-115 V 50-60 Hz	IEC plug EN 60320	20732205

Items supplied

Pump completely mounted, ready for use, with manual.

Accessories

- Mains cable US (20612065)

Technical data

Max. pumping speed 50 Hz (mbar)	2.3 m ³ /h
Max. pumping speed 60 Hz (cfm)	1.5 cfm
Ultimate vacuum	4 mbar / 3 torr
Number of heads	2
Number of stages	2
Permissible ambient temperature range (operation)	10 - 40 °C
Permissible ambient temperature range (storage)	-10 - 60 °C
Max. outlet pressure (abs.)	1.1 bar
Inlet connection	small flange KF DN 16
Outlet connection	Silencer / G1/4"
Rated motor power	0.18 kW
Rated speed 50/60 Hz	1500/1800 min ⁻¹
Protection class IEC 60529	IP 40
Dimensions (L x W x H)	246 mm x 242 mm x 198 mm
Weight	11.4 kg
Noise (sound pressure level) in dBA at 50 Hz or 1500 rpm/62% (VARIO)/1500 rpm (VARIO-SP)/12500 Upm (VACUU·PURE®)	47 dBA
ATEX conformity	II 3/- G Ex h IIC T3 Gc X Internal Atm. only
NRTL certification	Yes

Pumping speed graph at 50 Hz

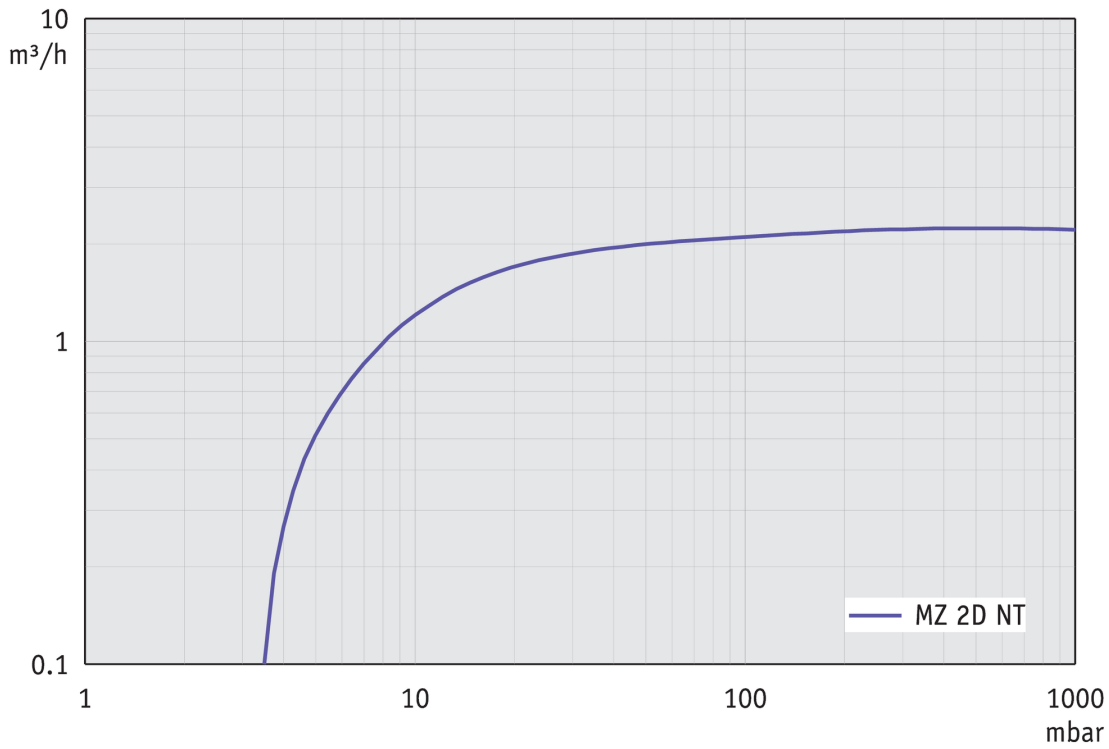

Pump down graph at 50 Hz (10 l volume)

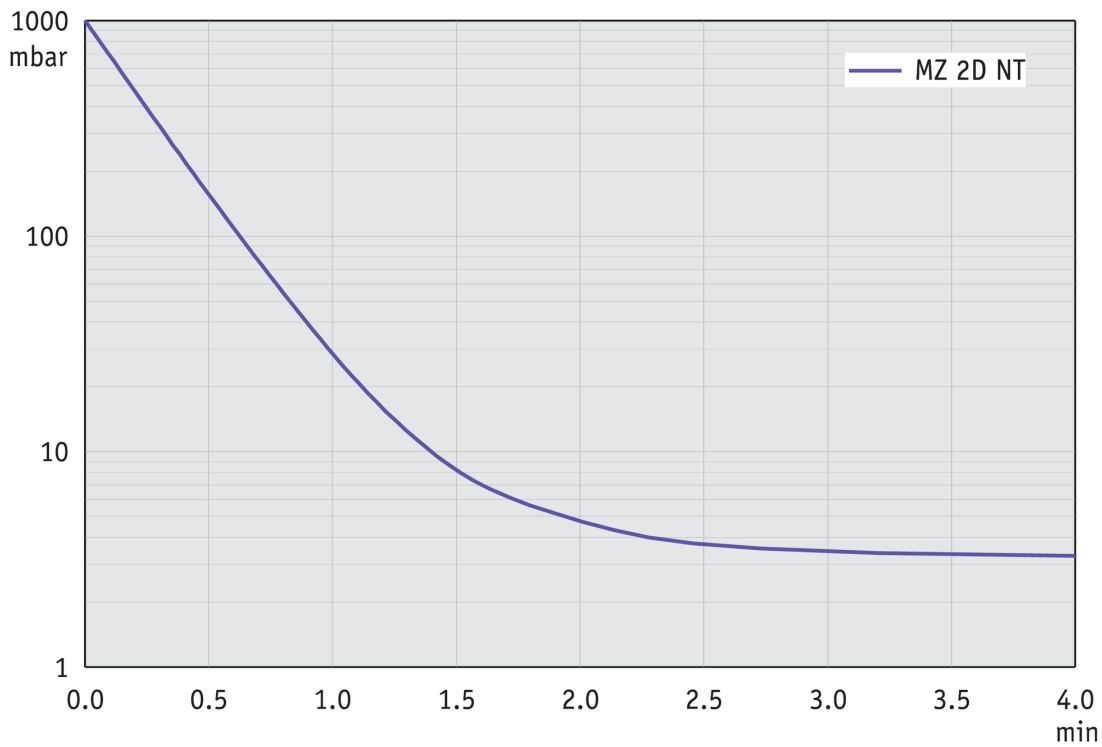

Pumping speed graph at 60 Hz

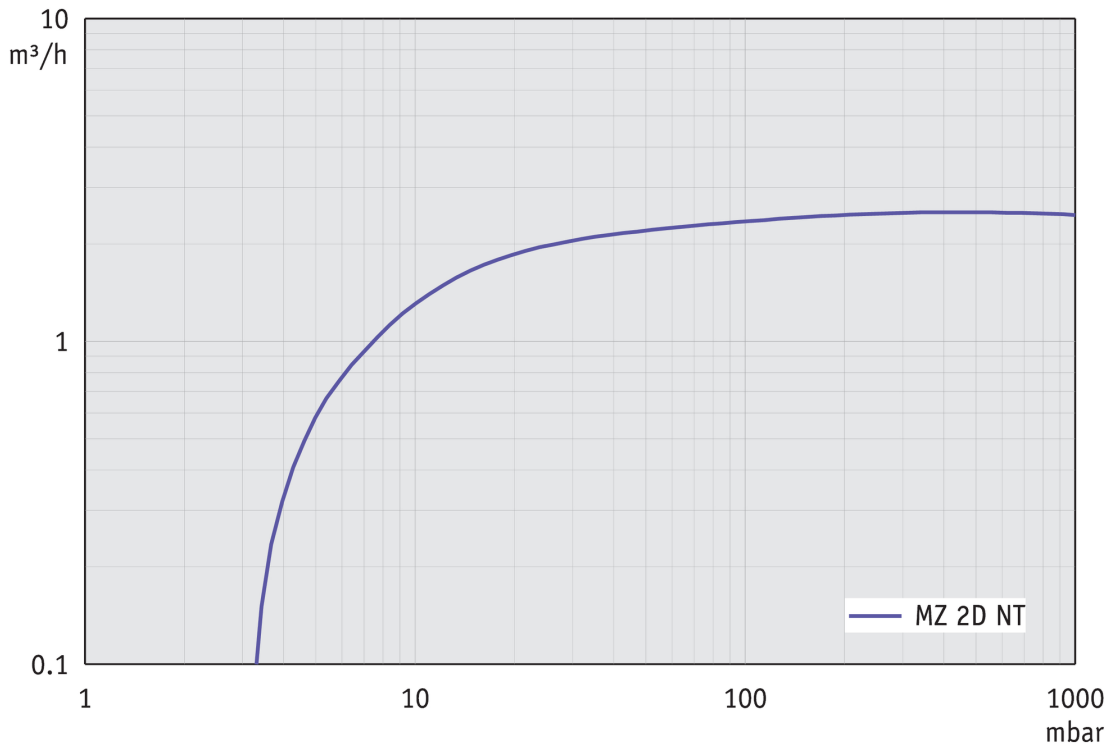

Pump down graph at 60 Hz (10 l volume)

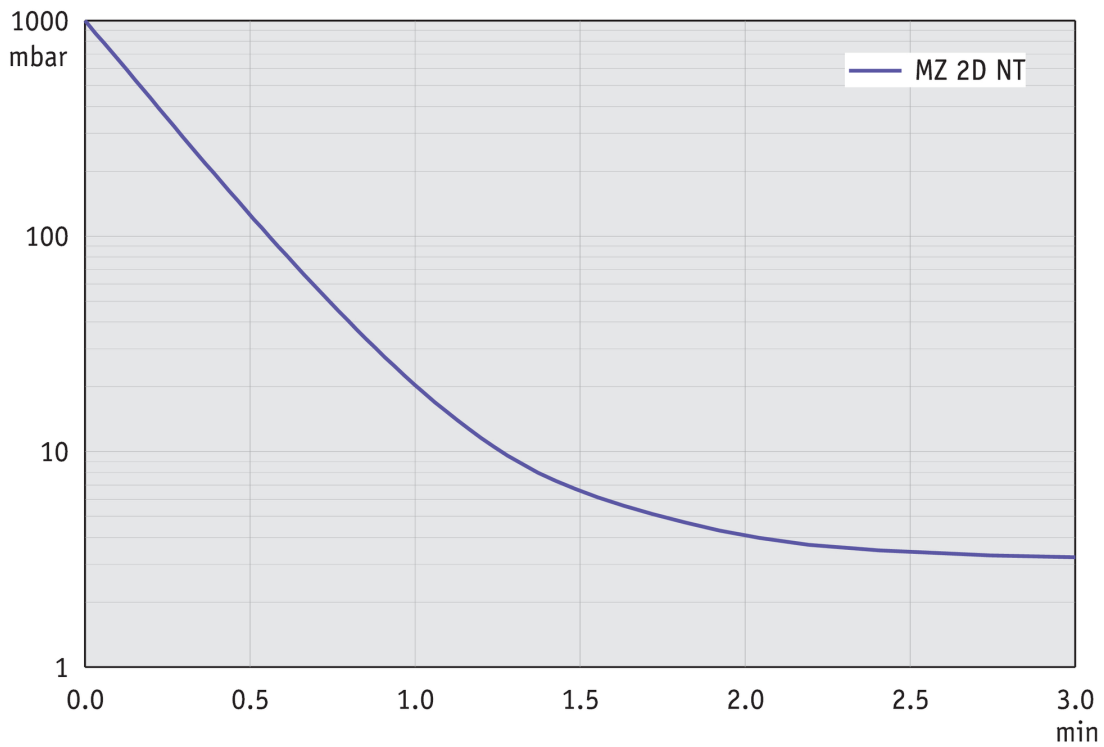

Dimension sheet



Das Eigentums- u. Urheberrecht an dieser Zeichnung bleibt uns vorbehalten.

All rights reserved by VACUUBRAND GMBH + CO KG

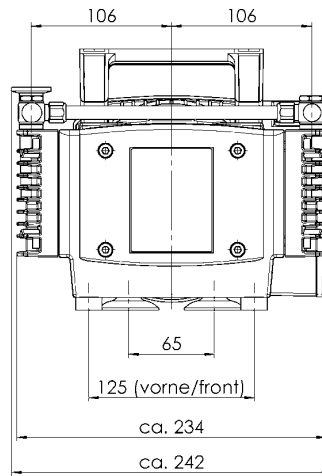
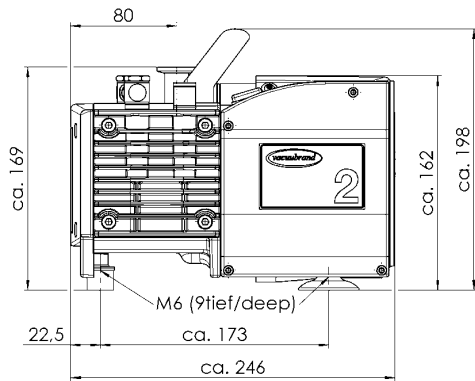

IN - Kleinflansch DN 16
IN - Small flange NW 16

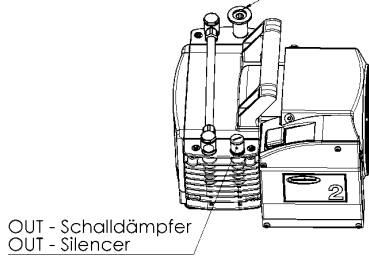

Maßblatt / Dimensions
MZ 2D NT

VACUUBRAND.

Alle Maße in mm
Technische Änderung vorbehalten

All dimensions in mm.
Technical data are subject to change
without notice

10000018753-000-04

VACUUBRAND GMBH + CO KG
P.O. Box 1664
97877 Wertheim
T +49 9342 808 5550
F +49 9342 808 5555

info@vacuubrand.com
www.vacuubrand.com

VACUUBRAND®

VACUUBRAND is part of the Brand group, a manufacturer of high-quality and innovative laboratory equipment and vacuum technology with a global team of approx. 1,000 employees.

With highly motivated and qualified employees, we manufacture the world's most comprehensive product family for vacuum generation, measurement and control for the rough and fine vacuum range in the laboratory.

All with one goal:

Enabling our customers to run reliable, safe and efficient processes. This is why we commit ourselves to continuous innovation, first-class performance, and outstanding quality.

Engineering excellence is central to our ability to deliver products and solutions renowned for their quality, durability, and reliability. Innovative technology, high quality materials and extensive testing deliver unmatched performance - engineered and manufactured in Germany.

Together with you, our experts will find the best solution for your application and provide you with first-class service along the way.

BRAND (Shanghai) Trading Co., Ltd.
Shanghai, China

T +86 21 6422 2318
info@brand.com.cn
china.brand.com.cn

BRAND Scientific Equipment Pvt. Ltd.
Mumbai, India

T +91 22 42957790
customersupport@brand.co.in
www.brand.co.in

BRANDTECH® Scientific, Inc.
Essex, CT. United States of America

T +1 860 767 2562
info@brandtech.com
www.brandtech.com