

VARIO® chemistry pumping unit PC 3010 NT VARIO select

[Link to the website](#)



Product description

The PC 3010 NT VARIO select pumping unit precisely controls the vacuum level in order to achieve unparalleled process control. With its combination of high pumping speed and fractional millibar ultimate vacuum, this pump is suitable for demanding applications with even high boiling point solvents at low temperatures. This pump is regularly used to support floor-standing rotary evaporators, vacuum drying ovens, distillation columns, and other similar work in miniplants, kilo labs, and scale-up facilities. The integrated VACUU-SELECT controller provides an easy-to-use, application based interface that covers all common lab applications. The VACUU-SELECT controller has you covered. Use manual set-point-control for simple processes, run fully automated distillations, or create your own application with simple drag-and-drop editing. For solvent evaporation, the VACUU-SELECT controller continuously detects the boiling point and automatically adjusts the vacuum process as necessary. In addition, the VARIO control algorithm maintains the desired vacuum level by running the motor only as fast as necessary. This prevents bumping and foaming, makes the pump whisper quiet, and extends maintenance intervals. The inlet separator, made of glass with a robust protective coating, prevents particles and liquid droplets from entering the pump, preventing damage and extending pump life. And the exhaust vapor condenser allows for nearly complete recovery of solvents when used with a chilled water line or recirculating chiller for economical recycling and environmental protection.

Performance features

- VACUU-SELECT vacuum controller with graphical user interface and predefined applications simplifies work in the laboratory
- automatic boiling point detection and adjustment of the vacuum for short process times
- ideal for evaporation of large amounts of high-boiling solvents even at low temperatures
- extraordinary diaphragm life for minimum operational and servicing costs
- excellent environmental compatibility through low energy consumption and efficient solvent recovery

Ordering data

Product name	Nominal mains voltage mains frequency	Plug type	Articleno.
PC 3010 NT VARIO select	200-230 V 50-60 Hz	CEE	25744850

Items supplied

Pumping unit completely mounted, ready for use, with manual.

Accessories

- Function extension for VACUU-SELECT controller VACUU-SELECT User Management (20700900)
- Clamping ring for small flange KF DN 20/25 (20660001)
- External centring ring for small flange KF DN 20/25 (20660196)
- Vacuum tubing PVC with internal stainless steel spiral, with small flanges KF DN 25 (20686021)
- Fluid level sensor for round bottom flask 500 ml 500 ml (20699908)
- Cooling water valve VKW-B (20674220)
- Air admittance valve VB M-B (20674217)

Technical data

Max. pumping speed 50 Hz (mbar)	12.8 m ³ /h
Max. pumping speed 60 Hz (cfm)	7.5 cfm
Ultimate vacuum	0.6 mbar / 0.45 torr
Ultimate vacuum with gas ballast	1.2 mbar / 0.9 torr
Number of heads	8
Number of stages	4
Vacuum controller	VACUU·SELECT
Permissible ambient temperature range (operation)	10 - 40 °C
Permissible ambient temperature range (storage)	-10 - 60 °C
Max. outlet pressure (abs.)	1.1 bar
Inlet connection	Small flange KF DN 25 / hose nozzle DN 15 mm
Outlet connection	Hose nozzle DN 8-10 mm
Coolant connection	2 x hose nozzle DN 6-8 mm
Rated motor power	0.53 kW
Motor speed range	30 - 2400 min ⁻¹
Protection class IEC 60529	IP 40
Dimensions (L x W x H)	616 mm x 387 mm x 450 mm
Weight	29.7 kg
Noise (sound pressure level) in dBA at 50 Hz or 1500 rpm/62% (VARIO)/1500 rpm (VARIO-SP)/12500 Upm (VACUU·PURE®)	47 dBA
ATEX conformity	II 3/- G Ex h IIC T3 Gc X Internal Atm. only
NRTL certification	No
Interface	Ethernet (RJ45): Modbus TCP / USB (Type A): Data transfer, software update, RS-232 (additional adapter required)

Pumping speed graph at 50 Hz

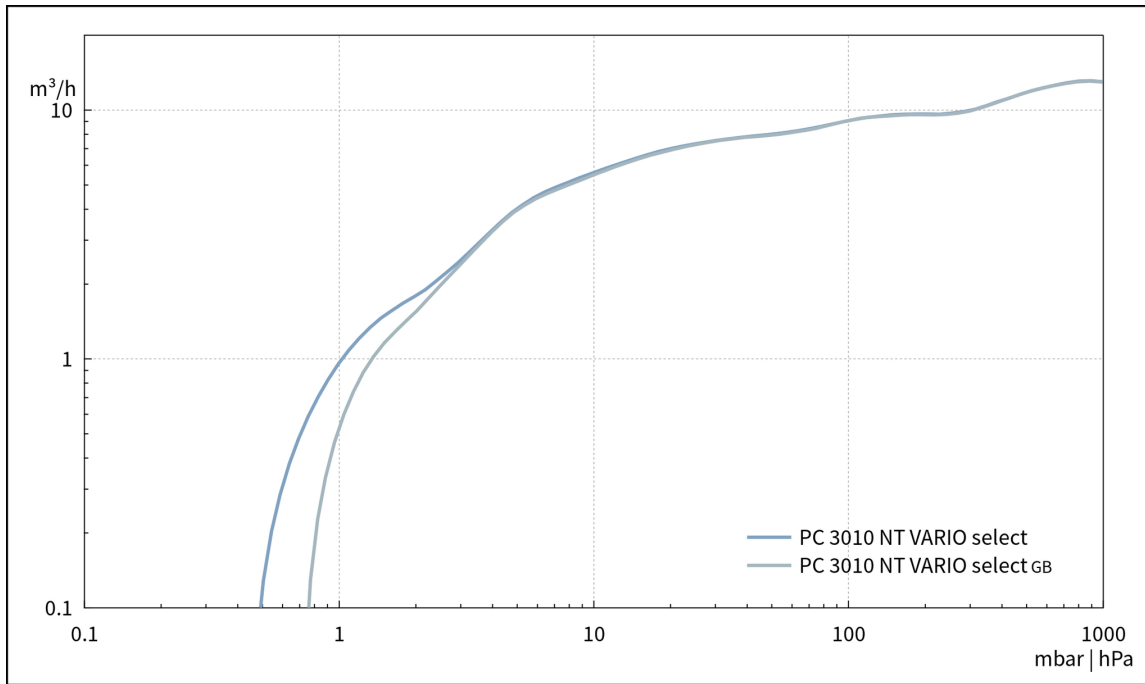

Pump down graph at 50 Hz (100 l volume)

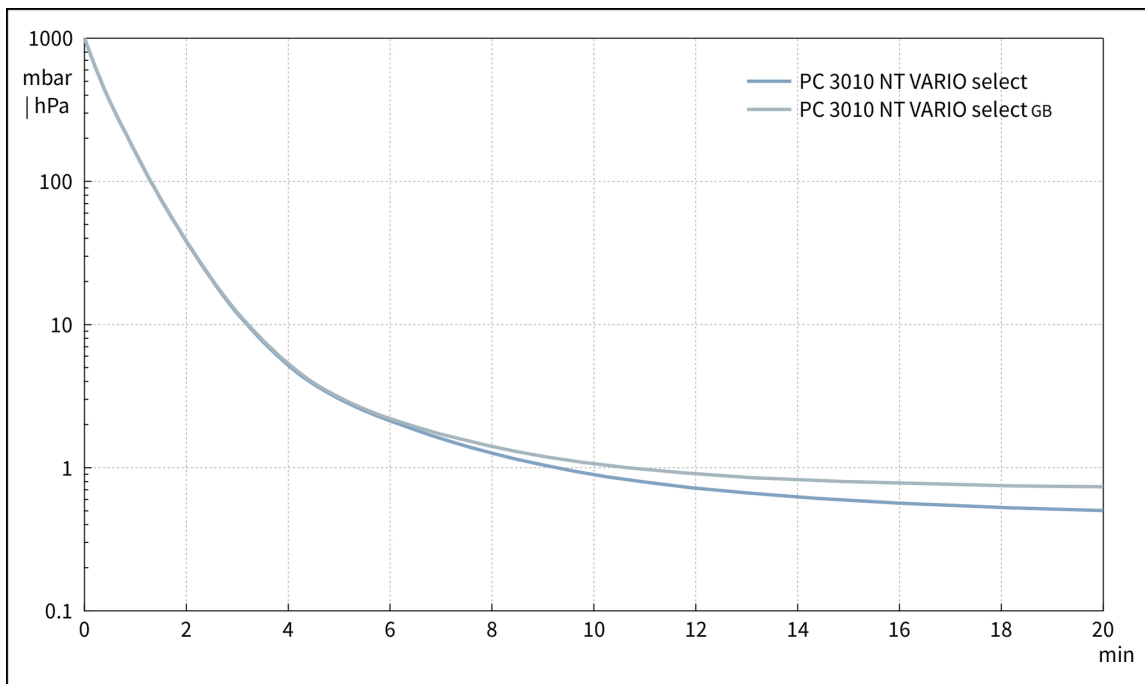

Pumping speed graph at 60 Hz

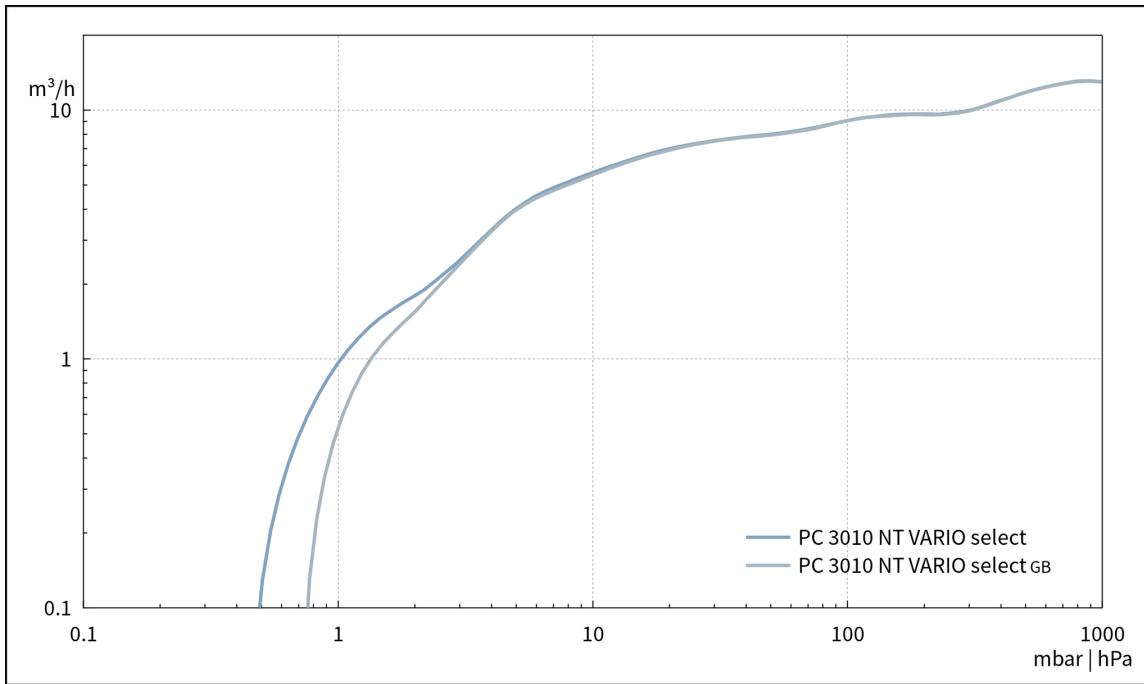

Pump down graph at 60 Hz (100 l volume)

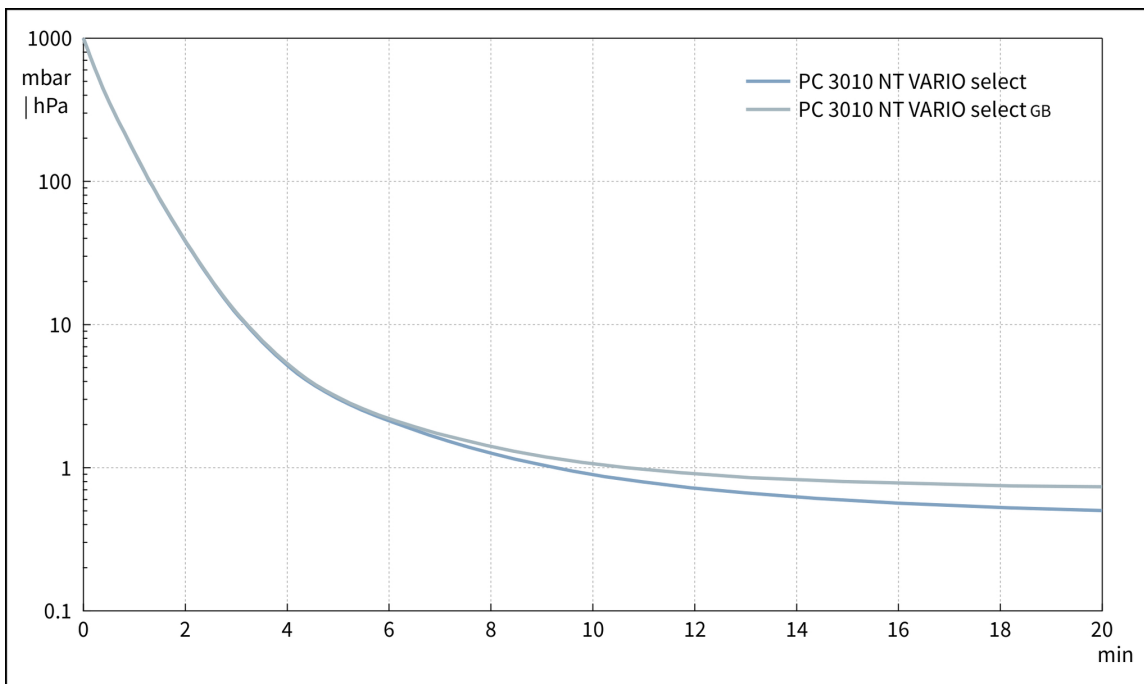

Dimension sheet

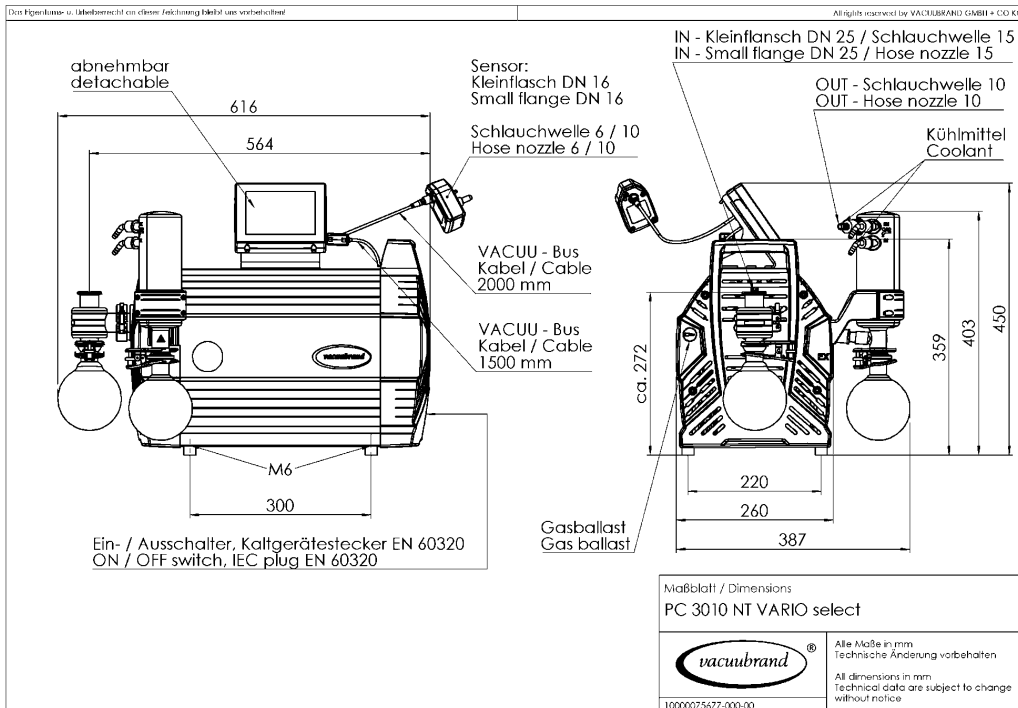

VACUUBRAND GMBH + CO KG
P.O. Box 1664
97877 Wertheim
T +49 9342 808 5550
F +49 9342 808 5555

info@vacuubrand.com
www.vacuubrand.com

VACUUBRAND®

VACUUBRAND is part of the Brand group, a manufacturer of high-quality and innovative laboratory equipment and vacuum technology with a global team of approx. 1,000 employees.

With highly motivated and qualified employees, we manufacture the world's most comprehensive product family for vacuum generation, measurement and control for the rough and fine vacuum range in the laboratory.

All with one goal:

Enabling our customers to run reliable, safe and efficient processes. This is why we commit ourselves to continuous innovation, first-class performance, and outstanding quality.

Engineering excellence is central to our ability to deliver products and solutions renowned for their quality, durability, and reliability. Innovative technology, high quality materials and extensive testing deliver unmatched performance - engineered and manufactured in Germany.

Together with you, our experts will find the best solution for your application and provide you with first-class service along the way.

BRAND (Shanghai) Trading Co., Ltd.
Shanghai, China

T +86 21 6422 2318
info@brand.com.cn
china.brand.com.cn

BRAND Scientific Equipment Pvt. Ltd.
Mumbai, India

T +91 22 42957790
customersupport@brand.co.in
www.brand.co.in

BRANDTECH® Scientific, Inc.
Essex, CT. United States of America

T +1 860 767 2562
info@brandtech.com
www.brandtech.com